

Anti-Terrorism Technologies & Hazard Reduction With Protective Glazing

Updated May 2003

Joseph L. Smith
Vice President
Director of Security Consulting Services
Applied Research Associates, Inc.
119 Monument Place
Vicksburg, MS 39180

This paper is a brief introduction and overview of some of the significant steps made in the development of technologies and procedures principally since the 1995 bombing of the A.P. Murrah Federal Building in Oklahoma City. Terrorism by its very nature is random and may encompass an endless array of attack possibilities. This paper specifically discusses the advances made to date in the area of protecting against bombs with a focus on protective glazing. While weapons of mass destruction such as chemical and biological devices are frequently discussed in the news, simple and readily available explosive devices generally remain the terror weapon of choice.

Background

In years past, blast resistant design was typically only used for facilities that housed or were in close proximity to explosive material or were known targets of attack. Munitions plants and storage facilities, strategic military and/or government facilities, and gas/oil refineries are a few examples of facilities that might have been designed specifically to resist blast. However, we are living today in an environment of enhanced risk that requires protective design and the management of risk for most facilities. This state of risk, punctuated by several major events over the past two decades, has led the Federal government to require blast resistant and hazard mitigating design for all new Federal facilities both within the United States and overseas. Some agencies are also now applying protective design standards to existing and new leased facilities.

Some of the major terrorist events that have helped to shape the way we, as a nation, have responded to terrorism include:

1983 & 1984 – On April 18th, a suicide car bomber attacked the US Embassy in Beirut Lebanon killing 17 Americans. The US Marine barracks in Beirut was subsequently bombed on October 23rd killing 241 American serviceman. On December 10th bombers hit the US and French embassies in Kuwait killing 5 and injuring 86. Finally the annex of the US embassy in Beirut was bombed on September 20th killing 16 and injuring the ambassador. This string of events initiated protective design programs both within the Department of Defense (DoD) and the Department of State.

1988 – A terrorist bomb destroyed Pan Am Flight 103 over Lockerbie, Scotland on December 21, 1988 killing 270 people. This event changed how the Federal Aviation Administration viewed terrorism and led to heightened security at US airports. This event helped initiate research and development on means to reduce hazard and risk associated with the National Airspace System.

1993 – On February 26, 1993, the bombing of the World Trade Center resulted in the deaths of 6 and injuries to over 1000. The bombing was the first large attack carried out on US soil by terrorists from a foreign country. This bombing opened the eyes of the American public to the possibility that this type of event could happen inside the United States. Members of terrorist cells were arrested and successfully prosecuted for participation in this attack as well as for planning future attacks against the tunnels and bridges of New York.

1995 - The A. P. Murrah Federal Building in Oklahoma City was bombed on April 19, 1995. One hundred and sixty-eight people were killed and over 500 others were injured. Prior to this event, the Murrah Building and other similar government facilities were not considered at risk. This bombing opened the eyes of the US Government to the fact that Federal buildings across this country are targets simply because these facilities are a symbol of the United States. This bombing fundamentally changed how we deal with terrorism as Presidential Decision Directives, Executive Orders, and other legislation mandated a response to reduce risk.

1996 – In June of 1996, Khobar Towers in Dhahran, Saudi Arabia was bombed killing 19 airmen. Thirteen years after a suicide car bomber killed 241 US Marines in Beirut, the armed forces of this country were once again reminded that American servicemen overseas are vulnerable to terrorist attack. DoD initiated a major force protection initiative after this event.

1996 to 1998 – Eric Robert Rudolph allegedly committed the Centennial Olympic Park bombing in Atlanta on July 27, 1996. He is subsequently charged with the double bombing at the Sandy Springs Professional Building in North Atlanta on January 16, 1997, the double bombing at The Otherside Lounge in Atlanta on February 21, 1997, and the New Woman All Women Health Care Clinic in Birmingham, Alabama on January 29, 1998. This bomber placed secondary bombs designed to kill and maim rescuers, paramedics, firefighters and police officers who rushed to the scene to help, and in doing so set in motion new training requirements for first responders.

1998 - The US Embassies were bombed in Kenya & Tanzania on August 7th. Two hundred and twenty-four people were killed while nearly 5,000 sustained injuries in these al Qaeda sponsored bombings. Prior to these bombings, both of these diplomatic posts were considered by the State Department to be low risk facilities. Once again, the lessons from Beirut had faded into the background. After these bombings, the State Department declared that there is no such thing as a low risk post. A major security upgrade program was once again put in place.

2000 – On October 12th, the USS Cole was bombed in the port of Yemen. This event reinvigorated the Force Protection efforts of the US military and was a clear indication that Osama bin Laden and his al Qaeda terrorist network remained a significant problem that would not go away on its own.

2001 – The September 11th attacks upon the United States killed thousands and disrupted the American economy. While the attacks upon the Pentagon and the World Trade Center did not involve explosives, the airplanes involved were clearly used as guided missiles that had explosive effects upon their targets (impact, deflagration and fire). These events significantly altered the American commitment to face the security threats and meet the challenges facing freedom and democracy worldwide. America declared a “new war” in a long and protracted fight to eradicate or at least minimize the terrorist threat.

It is evident that while the attacks of “9-11” were horrendous, they do not represent a departure from the ever-escalating environment of risk in which we live. This attack, however, being in the U.S., seen live on TV and resulting in the deaths of so many civilians was an event that cannot be easily forgotten.

2002 – 2003 The United States and its allies have proactively sought out terrorists and their sponsors worldwide. The war in Afghanistan and in Iraq were fought most notably to eliminate known sources of terrorist threats to our security and the security of our allies. These wars, while militarily successful, will require long term American commitment and will, no doubt, not eliminate the threat of terrorism. For at least the short term, the terrorist threat to the United States will remain high.

Criteria Overview

As with the tragedies of September 11th, the Federal Government moved swiftly to respond to the Oklahoma City bombing. The day after the event, the President of the United States directed the Department of Justice to assess the vulnerability of federal facilities in the United States to acts of violence. This began the General Services Administration's (GSA's) focused efforts to address security in light of known terrorist threats. Due to the urgency of the situation, a report was required within a short 60 days. This report consisted of two parts: (1) a survey of the existing security conditions and (2) a first cut at minimum recommendations for security standards. A group of security specialists and representatives from the Department of Justice, the US Marshall's Service, General Services Administration, State Department, Social Security Administration, and Department of Defense worked together to complete the report entitled, "Vulnerability Assessment of Federal Facilities." This report, commonly referred to as the DOJ or Marshall's report, offered several important conclusions. This study and the subsequent Presidential Decision Directives (PDD 39, 62, and 63) and Executive Order 12977, related to anti-terrorism response, provided the motivation for the development of several GSA programs. A few of the DOJ report conclusions were:

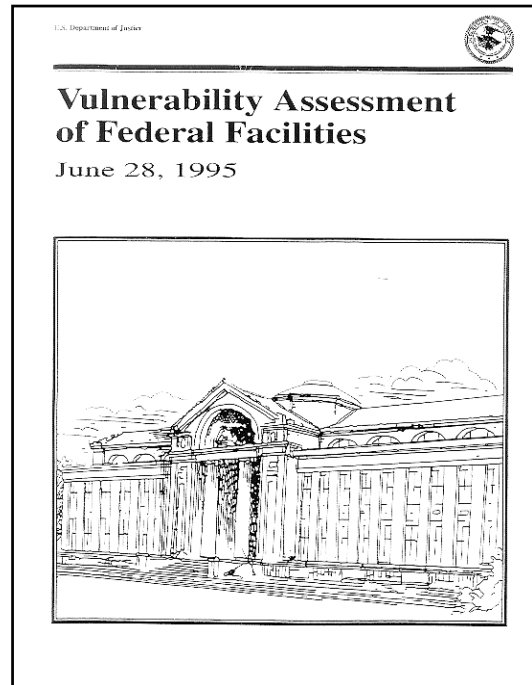

- Provide for application of shatter-resistant material to protect personnel and citizens from the hazards of flying glass as a result of impact or explosion.
- Review, establish, and implement uniform construction standards as it relates to security considerations. Blast protection standards should be reviewed and established.
- Classify buildings into five levels in order to evaluate security requirements. These five levels are:

Table 1. DOJ Report Security Levels.¹

| DOJ Security Level | Number of Federal Employees | Facility Size (ft ²) | Typical Tenants (examples only) |
|--------------------|---|----------------------------------|--|
| I | $N \leq 10$ | $A \leq 2,500$ | Small "store front" type operations |
| II | $10 < N \leq 150$ | $2,500 < A \leq 80,000$ | Lower risk agencies |
| III | $150 < N \leq 450$ | $80,000 < A \leq 150,000$ | Medium risk agencies like GSA field office ... |
| IV | $N > 450$ | $A > 150,000$ | Higher risk agencies like ATF, FBI, DEA, ... |
| V | Level IV profile & agency/mission critical to national security | See Level IV profile | Highest risk agencies like CIA HQ, the Pentagon, ... |

- The Interagency Security Committee (ISC) should be created by Executive Order to provide a permanent body to address continuing government-wide security concerns. The Federal Protective Service (FPS) should be authorized to chair and staff the ISC and be responsible for implementing and monitoring any ISC recommendations.

¹ **Department of Justice Report** – Commonly referred to as the DOJ report. After the Oklahoma City bombing, President Clinton directed the Dept. of Justice to conduct a study of the vulnerability of federal facilities to include recommendations. A report, "Vulnerability of Federal Facilities," was published on June 28, 1995.

- There should be a review of the risk assessment methodology in use by GSA prior to the Oklahoma City bombing. A group of security professionals from the various federal agencies should be formed to review and amend the current GSA assessment form.

Since the publication of this report, the GSA has put forth numerous initiatives to address the problems identified. With over 8,000 owned and leased facilities, the task of evaluating and implementing a prudent, effective and affordable approach to protecting the people in these open, public facilities is a large task. For example, approximately one-fourth of these facilities (~2,000) are federally owned and house about 55% of the people in GSA space. Best estimates indicate that there are over 35 million square feet of window glass in this subset of GSA buildings alone. Hence, protecting occupants from just the dangers of flying glass fragments that are generated in a bombing event is a large task. However, in order to protect the people within government space, it is important to remember that security protection issues must be examined as a whole. This includes threat determination, protection of site and facility perimeters, introduction of hardening measures that improve the performance of the facilities under abnormal loads, and mitigating the consequences of an attack. While important, issues like the glass fragment retention problem or the problem of retrofitting to prevent structural collapse, are only parts of the overall protection suite that is required.

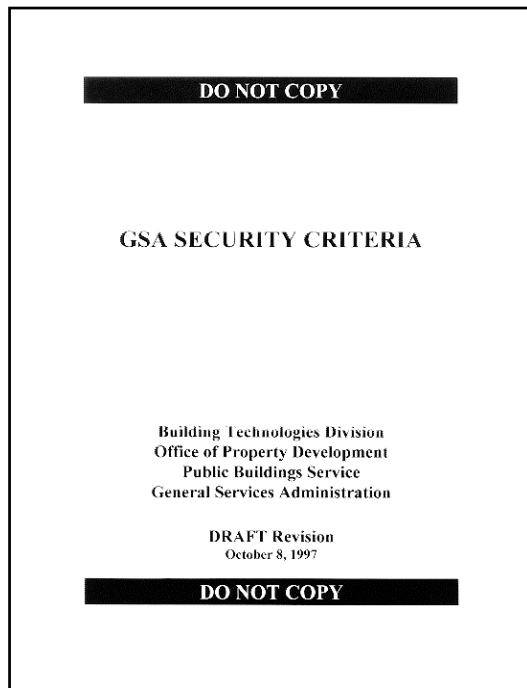

The DOJ report provided broad and general guidance. However, it did not provide criteria and standards by which existing facilities could be evaluated and new facilities could be designed. Hence, one of the first priorities for the GSA was to develop a performance-based standard or criteria. Drawing upon experts within government and the private sector, GSA produced the "GSA Security Criteria"² and published a working version for implementation on its facilities in January of 1997. An updated revision was issued on October 8, 1997. This document has been used in the development of several new facility designs and has been the basis of the performance standards used in retrofit analyses of existing buildings. The GSA Security Criteria set performance-based standards for the protection of people in open, civilian facilities. For the first time, this security document attempted to fully integrate security requirements throughout all functional areas and design phases of a facility. The table of contents (shown below) for the document is indicative of this full integration of security into the facility requirements:

| | |
|---|---|
| <p><u>Table of Contents</u></p> <p>Chapter 1</p> <p>Chapter 2</p> <p>Chapter 3</p> <p>Chapter 4</p> <p>Chapter 5</p> <p>Chapter 6</p> <p>Chapter 7</p> <p>Chapter 8</p> | <p><u>THE GSA SECURITY CRITERIA</u></p> <p>General Requirements</p> <p>Site Planning and Landscape Design</p> <p>Architecture and Interior Space Planning</p> <p>Structural Engineering</p> <p>Mechanical Engineering</p> <p>Electrical Engineering</p> <p>Fire Protection Engineering</p> <p>Electronic Security</p> |
|---|---|

Central to the creation of this important document and all subsequently developed technologies was the premise that the government owns or leases public facilities that must remain accessible. As Supreme

² "GSA Security Criteria," Building Technologies Division, Office of Property Development, Public Buildings Service, General Services Administration, Final Working Version, October 8, 1997, Limited Official Use Only.

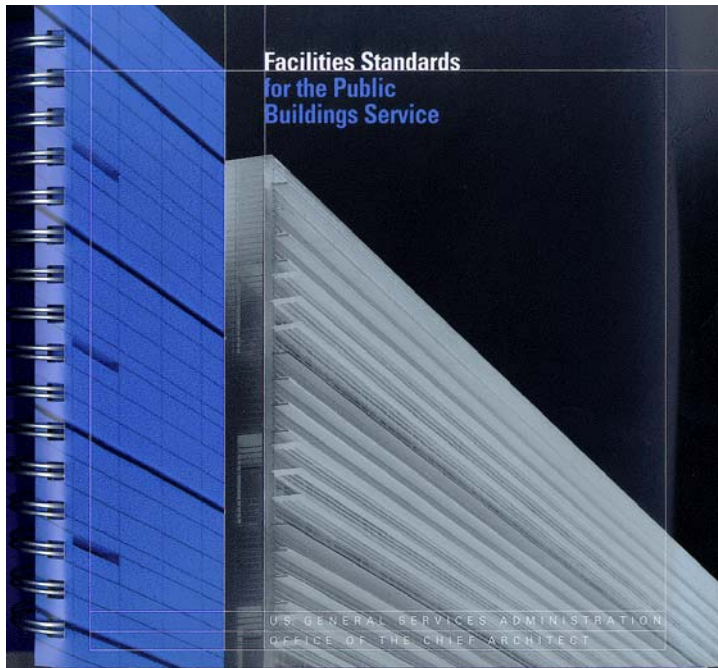

Court Justice Stephen Breyer once said, "Openness in Federal architecture is a symbol of inestimable value. Our government is not distant. It is a government of the people. And our public buildings must say they are about people and our democratic values."³ Given this constraint, the GSA recognized that some risks must be accepted. The task was to prevent an attack, if possible. If not, the goal was to mitigate the consequences of an event but not necessarily to eliminate all risk through fortress-like measures. This approach required the development of new technologies and performance-based criteria sensitive to the requirements of civilian facilities. Prior to GSA's work, blast protection focused on a limited number of facilities for such agencies as the Department of Defense (DOD) and the Department of State (DOS). GSA's facilities, unlike these other facilities, are open and intended for public access. Hence, performance-based measures were required as opposed to the heavy-hardening, prescriptive solutions generally applied to DOD or DOS facilities.



Subsequent to the release of GSA's Security Criteria, the GSA chaired an Interagency Security Committee (ISC) with the purpose of adapting GSA's Security Criteria for all federal agencies. The committee, composed of 26 member agencies, drafted the "ISC Security Criteria for New Federal Office Buildings and Major Modernization Projects."⁴ This document was

officially signed off as "final" by the ISC Chairman on May 30, 2001. The ISC document is largely the same as the GSA Security Criteria in the areas related to protection from blast. This is especially so in the area of mitigating risk from window glass fragments. Most differences relate solely to the criteria format and terminology. For example, the ISC Medium level of protection is generally equivalent to the

³ Supreme Court Justice Stephen Breyer, Keynote Address at the "Balancing Security and Openness" Symposium, Washington, D.C., November 30, 1999.

⁴ "ISC Security Criteria for New Federal Office Buildings and Major Modernization Projects," The Interagency Security Committee, May 28, 2001, For Official Use Only. The ISC Chairman officially signed this document as final on May 30, 2001.

GSA Security Criteria Level C protection. Likewise, the ISC Higher level is generally equivalent to the GSA Level D.

These GSA and ISC Security Criteria apply to new construction of general-purpose office buildings and new or lease-construction of courthouses occupied by Federal employees in the United States and not under the jurisdiction and/or control of the Department of Defense. The criteria also apply to lease-constructed projects being submitted to Congress for appropriations or authorization. They do not apply directly to airports, prisons, hospitals, clinics, border patrol stations, and ports of entry; or to unique facilities, such as those classified by the DOJ Vulnerability Assessment as Level V (the Pentagon, CIA headquarters, etc). The GSA does not generally control facilities that are designated as DOJ Level V. Where prudent and appropriate, the criteria apply to major modernization (i.e., retrofit and renovation) projects. The principles contained in the documents may be considered for projects not meeting the foregoing definitions. The criteria are intended for use by design and security professionals in the development of detailed project requirements.

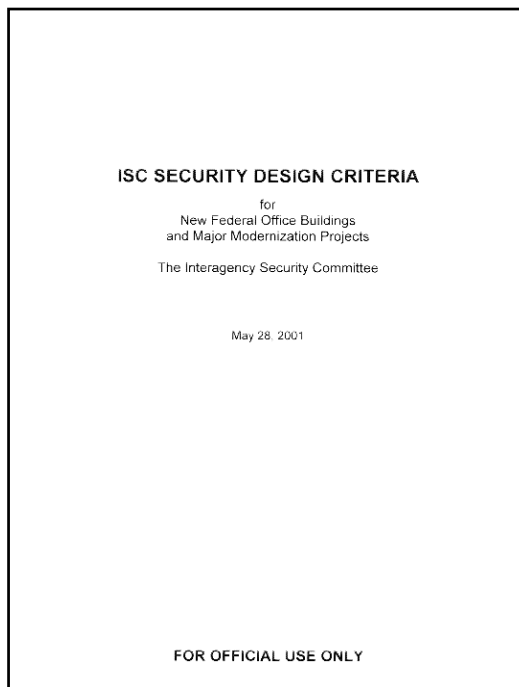

A large portion of the GSA/ISC documents was excerpted and recently published by GSA's Public Building Service in PBS-P100, "Facilities Standards for the Public Buildings Service."⁵ This document (cover shown on the previous page) is intended for use in all new facilities or alterations for GSA owned or leased construction, and contains policy and criteria to be used in programming, design, and documentation of GSA buildings. This document is not restricted and is intended for a wide public audience.

In order to transfer this new technology to those who need to implement designs and assessments, GSA has provided training sessions, has worked to form partnerships with industry, and maintains a secure technology-transfer website, www.oca.gsa.gov. This secure website has various levels of security ranging from unrestricted public access to fully controlled and monitored access. This website has facilitated the progress of GSA's efforts to provide the necessary protection for its facilities by getting critical information into the hands of those with a "need-to-know."

As previously discussed, the GSA has assisted in leading the U.S. Government effort to establish security criteria and performance-based standards for civilian facilities as the Chair of the Interagency Security Committee. The GSA and ISC Security Criteria documents address all aspects of building security. These documents should serve as valuable references for those involved with the blast and security design of any government facility. GSA has made these documents available to other agencies who have in-turn developed customized versions that are applicable to their specific mission needs. While most agencies directly use the GSA and ISC Security Criteria documents, others such as the State Department, the Department of Defense and the FAA have published separate documents.

The US Department of State has protected its newly constructed facilities from the effects of blast for many years. Following the terrorist bombings of the embassy and US Marine facilities in Beirut, Lebanon in 1983, a significant project known as the Inman Program was undertaken to develop criteria for new construction and to implement renovations that include security improvements. The State Department's program was reinvigorated with the bombings of US Embassies in Kenya and Tanzania in 1998. Over

⁵ "Facility Standards for the Public Buildings Service," PBS-P100, U.S. General Services Administration, Office of the Chief Architect, Revised November 2000.

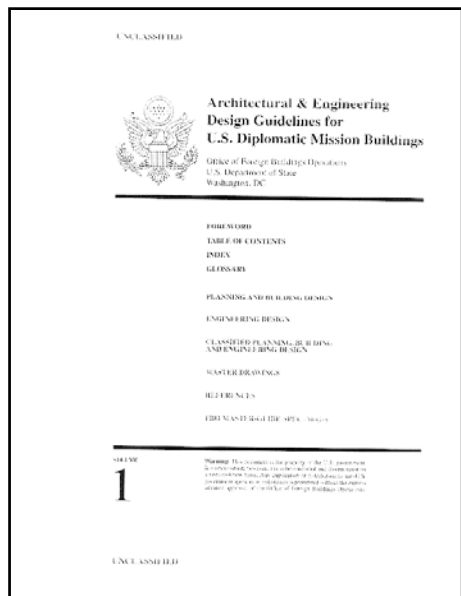

the course of the State Department's experience with protecting its facilities from blast, their criteria has evolved and changed as necessary to meet the ever-increasing environment of enhanced risk. State's current criteria is included in a five-volume document referred to as the "Architectural & Engineering Design Guidelines for U.S. Diplomatic Mission Buildings."⁶ In general, the State Department's protection requirements for blast are significantly more stringent than those included in the GSA and ISC Security Criteria. The State Department requires higher levels of protection from larger sized explosive devices. These requirements are performance-based, but do have more prescriptive solutions than are required by the GSA/ISC Security Criteria. This is appropriate for these diplomatic facilities since they are far fewer in number than those controlled by GSA, they are not open, public facilities, and they are known targets of active groups in overseas locations.

The US Department of Defense has also developed new criteria

for the protection of its facilities and troops in the field, "DoD Minimum Antiterrorism Standards for Buildings."⁷ DOD's efforts in the area of anti-terrorism were most recently accelerated in response to large-scale, asymmetric attacks upon the military forces of the United States by terrorists in the Middle East. Recent examples include the bombing of the military barracks in Dhahran, Saudi Arabia by forces loyal to international terrorist Osama Bin Laden (1996), the bombing of the USS Cole in the Port of Yemen in 2000, and the September 11th attack on the Pentagon. The military's protection program is known as Force Protection. This program and its requirements are more stringent than those required by the GSA/ISC Security Criteria. The military does not generally

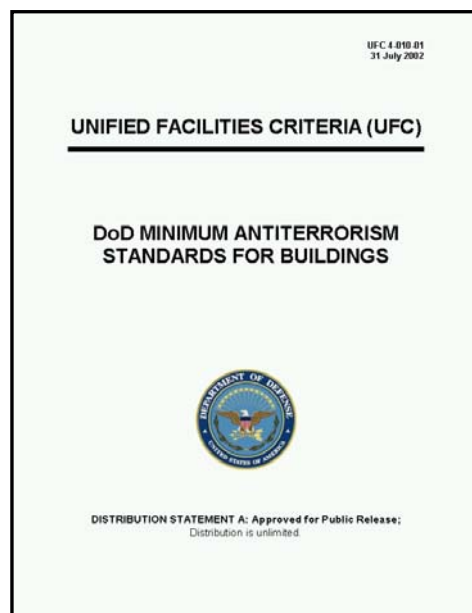

operate open, public facilities, and is primarily concerned about mission capability, mission

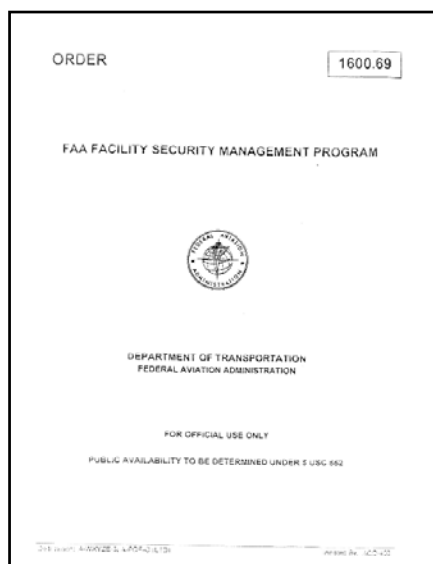

effectiveness, and force readiness. DOD's criteria document generally considers larger explosive devices than does the GSA's. Finally, DOD requirements are significantly more prescriptive (not performance-based) in nature. In many instances, the DOD criteria has adopted parts of the GSA's criteria and the technology developed by GSA especially in the area of preventing progressive collapse.

The US Department of Transportation Federal Aviation Administration (FAA) is responsible for protecting the critical facilities that support the National Airspace System. These facilities include the nation's air traffic control towers, Air Route Traffic Control Centers, National Network Control Centers, and other support buildings like the FAA and DOT National and Regional Headquarters. The FAA's criteria requires that all facilities rated as

⁶ "Architectural & Engineering Design Guidelines for U.S. Diplomatic Mission Buildings." The Office of Foreign Buildings Operations (now Overseas Building Operations – OBO), U.S. Department of State, Washington D.C, produced this document. (Unclassified).

⁷ "DoD Minimum Antiterrorism Standards for Buildings." Portions of this document are labeled For Official Use Only. Unified Facilities Criteria (UFC 4-010-01), July 31, 2002.

Level 3 or higher by the DOJ report have blast protection measures. "FAA Order 1600.69 – FAA Facility Security Management Program,"⁸ uses a larger explosive threat size than the GSA/ISC criteria. It is performance-based and relies heavily upon references to the GSA/ISC Security Criteria documents. For the most part, FAA has adopted in whole, the GSA's performance-based standards. The primary difference is that the threats used by FAA are larger than those typically considered for GSA facilities. This is primarily due to the verified nature of the threat to aviation facilities and due to the fact that FAA does not generally operate facilities that support the NAS in an open, public manner. The Transportation Security Administration (TSA) has assumed control of security at the nation's airports. They have issued enhanced security requirements known as "Bomb Incident Prevention Plan – Standard Operating Procedures" for ensuring aviation security.⁹

Assessments & Risk Management

All facilities face a certain level of risk associated with natural events, accidents, or intentional (criminal or terrorist) acts to cause harm. Regardless of the nature of the threat, facility owners have a responsibility to limit or manage risks from these threats to the extent possible. The first step in protecting a facility or other asset should be to conduct a risk assessment. Assessment terminology is often misused and misunderstood. The following are generally accepted descriptions of different assessment types:

Threat Assessment – A threat assessment evaluates the potential aggressors and the type of tactics that they are most likely to employ. The threat assessment should consider a complete spectrum of threats to include natural (i.e., earthquakes, floods, fires, tornados, hurricanes, etc.) and man-made (i.e., accidents, criminal acts, terrorist acts, etc.). For threats involving explosives and other weapons of mass destruction, the threat assessment should quantify the type and/or size of device. The result of the threat assessment is a list of credible threats and/or attack scenarios.

Physical (Information) Security Assessment – A physical (information) security assessment usually consists of an evaluation of the existing countermeasures. This includes fixed countermeasures (e.g., locks and barriers, or firewalls and routers) as well as operational and procedural countermeasures. A physical (information) security assessment generally includes suggestions for upgrades to existing countermeasures, as required to meet a desired protection goal. Often, a physical (information) security assessment utilizes a set of minimum standards as a guide for evaluating existing conditions and making upgrade recommendations.

Vulnerability Assessment – A vulnerability assessment quantifies the potential impact from specific threat scenarios based on existing or planned conditions. The vulnerability assessment should evaluate potential damage to assets and injury to people from each attack scenario. This provides a baseline for determining the potential benefits from various security and/or structural upgrades.

Risk Assessment – A risk assessment incorporates the threat assessment, the physical and/or information security assessment, and the vulnerability assessment to evaluate the potential risks associated with each threat. The objective of the risk assessment is to quantify the existing risks and to make recommendations to reduce high and/or moderate risks to the extent possible. A risk assessment may or may not include detailed vulnerability assessments performed by subject matter experts (i.e., a blast assessment, chem/bio assessment, lighting assessment, CCTV assessment, etc.). Obtaining these detailed assessments may be part of the recommendations from a risk assessment. For planned facilities, a risk assessment can be used to help in the development of design criteria.

All of the above assessment types in conjunction with the implementation of assessment recommendations help to provide risk mitigation. Risk mitigation involves reducing risks through lowering

⁸ FAA Order 1600.69 "FAA Facility Security Management Program." This document is For Official Use Only and is available from FAA/ACO-400.

⁹ TSA SOP "Bomb Incident Prevention Plan – Standard Operating Procedures (SOP)," January 7, 2003. This document is Sensitive Security Information and is protected by 49 CFR Part 1520.

the potential impact of loss from a successful event and/or reducing vulnerability to an attack. As an example, risk mitigation for a vehicle bombing attack may include:

- Application of glass fragment retention film on windows. While this does not reduce the vulnerability to an attack, it does potentially reduce the amount of hazardous flying glass produced by a successful event and therefore lower the impact of loss from serious injury and or death.
- Eliminating all unscreened vehicle traffic within a defended standoff distance. This also lowers the potential impact of loss from a successful event by providing standoff and thereby reducing the extent of damage to the facility. This could also reduce the vulnerability to an attack as a potential aggressor may choose not to attack this facility because the potential for causing catastrophic damage is low.

Threat/vulnerability assessments and risk analysis can be applied to any facility and/or organization. The federal government has been utilizing varying types of assessments and analyses for many years. The GSA's Federal Protective Service (FPS) is utilizing a methodology entitled Federal Security Risk Management (FSRM). This process is graphically summarized on the following page. GSA is using the process to assess over 8000 federally owned and/or leased facilities. The Internal Revenue Service (IRS) has also adapted the FSRM methodology to assess over 700 facilities housing IRS employees. Other agencies that have used this process to assess some of their facilities include the U.S. Department of Agriculture and the Smithsonian Institution. The Social Security Administration has also trained over 50 of its facility managers and security specialists to apply this process. Applied Research Associates, Inc. developed a computerized version of the process (***FSR-Manager***) that guides the assessment team, provides interactive help to users, automatically writes formatted reports and develops a database of facility risk assessment information.

FEDERAL SECURITY RISK MANAGEMENT

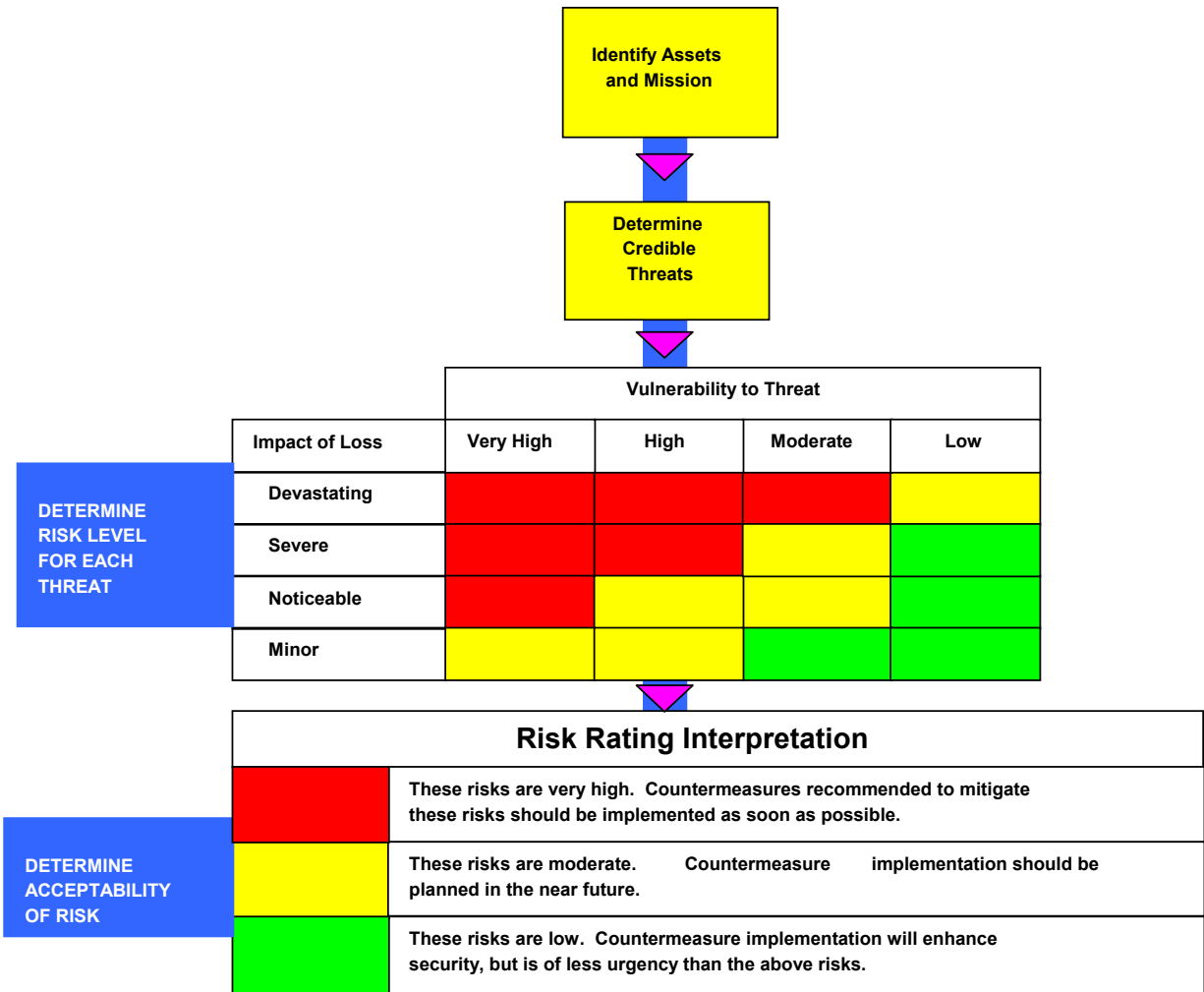

PURPOSE

- I. To evaluate the risk to the facility.
- II. To quantify risk and establish what risks are acceptable.
- III. To determine what measures and costs are required to reduce unacceptable risks to an acceptable level.

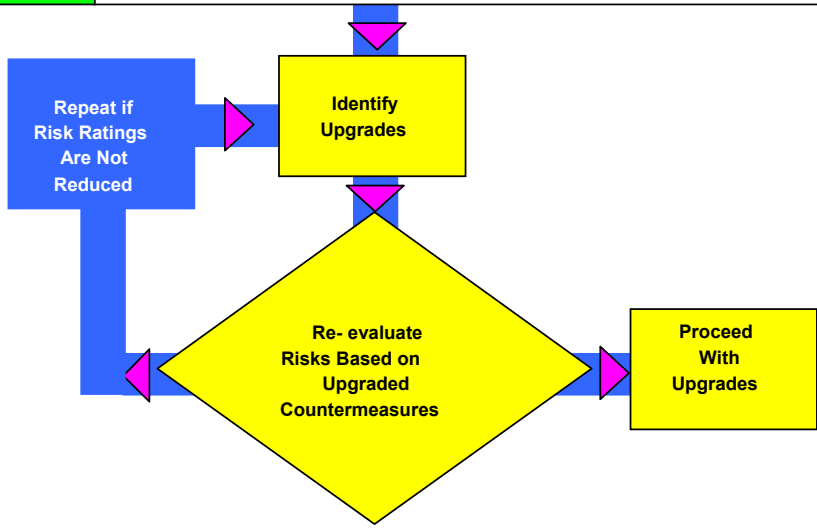

Terrorist Attack Using Explosives

Explosive events are much more common than most people realize. Table 2 presents the number of explosive events that occurred in the United States from 1993 through 1997. This information is from a database maintained by the Bureau of Alcohol, Tobacco and Firearms.

Table 2. Total number of explosive incidents in the US by type from 1993 to 1997.

| Type of Event | Total | Injured | Killed | Damage (\$) |
|--------------------------------------|---------------|--------------|------------|--------------------|
| Accidental Explosions (Non Criminal) | 150 | 513 | 101 | 34,932,299 |
| Attempted Bombings | 2,295 | 7 | 13 | 195 |
| Attempted Incendiary Bombings | 901 | 0 | 0 | 350 |
| Actual Bombings | 8,056 | 2,773 | 329 | 621,198,099 |
| Actual Incendiary Bombings | 2,308 | 192 | 35 | 24,749,148 |
| Recovered Explosives | 8,369 | 0 | 0 | 0 |
| Stolen Explosives | 426 | 0 | 0 | 0 |
| TOTAL | 22,505 | 3,485 | 478 | 680,880,091 |

Table 2 indicates that there were 8,056 actual bombings in the United States over this 5-year period. That is an average of about 1611 actual bombings per year or roughly 4 to 5 per day. The reason that many of these incidents go unpublicized is that the bombings involve small amounts of explosives. These events may make local headlines, but fail to attract national attention. Table 3 presents a partial list of the number of explosive incidents by state. The top 3 states are California, Illinois and Florida. California alone accounted for almost 20% of the total number of explosive incidents during that 5-year period.

Table 3. Total number of explosive incidents by state.

| State | Total | Rank |
|------------|-------|------|
| California | 4,390 | 1 |
| Illinois | 1,897 | 2 |
| Florida | 1,729 | 3 |
| Texas | 1,156 | 4 |
| Arizona | 919 | 5 |
| New York | 822 | 6 |
| Michigan | 782 | 7 |

Table 4 shows typical charge sizes for different explosive delivery methods. The van pictured is capable of delivering the charge sizes identified in the moving vehicle category. The very large truck bomb would not normally be considered when designing either commercial facilities or government facilities other than Department of Defense locations.

Table 4. Delivery methods and accompanying charge sizes.

|  | Explosive Threat | Charge Size(s) | Commons Size(s) Considered for Commercial or Non-DOD Facility |
|---|-----------------------|------------------|---|
| | Very Large Truck Bomb | 4000 < W < 25000 | Not considered |
| Moving Vehicle | 100 < W < 4000 | 100, 500, 1000 | |
| Stationary Vehicle | 100 < W < 4000 | 100, 500, 1000 | |
| Hidden on Vehicle | 1 < W < 220 | 50 | |
| Loading Dock | 1 < W < 100 | 50 | |
| Lobby / Public Access | 1 < W < 50 | 5, 10 | |
| Mail Room | 1 < W < 10 | 1, 5 | |

The best defense against death and injury from bombing attacks is to prevent the attack from occurring. History, however, has taught us that this is not always possible. Therefore, we must learn how to mitigate the hazards associated with this type of attack. The bombing events mentioned previously have provided limited data that can be utilized to learn how best to mitigate these hazards.

When a bomb detonates, the solid, liquid or gaseous explosive material undergoes an exothermic chemical reaction that releases tremendous amounts of energy in a very short period of time. This detonation creates a hot gaseous fireball that is a high temperature and pressure. In order to reach equilibrium with its surroundings, the material expands rapidly. This creates the shock wave that travels out from the detonation source. A detonation is illustrated below.



Detonation of an explosive device.
©2001 Applied Research Associates, Inc.

The blast pressure from an explosion decreases rapidly in magnitude with increasing distance from the explosion. In most cases, especially for design purposes, simplified methods may be used to estimate the blast loading. For design, the blast pulse is generally simplified and assumed to consist of a triangular shape. The overpressure is assumed to rise instantaneously to its peak value and decay linearly to zero overpressure (i.e., back to ambient pressure) in a time known as duration time. In this case, the area under the pressure-time waveform, or impulse, is simply the area of a triangle, or:

$$I = P * t_d / 2$$

Where I = impulse, psi-msec
P = peak pressure, psi
 t_d = duration time, msec

Note that both the pressure and the impulse (or duration time) are required to define the blast loading. In order to obtain these values, the blast consultant may use a number of available tools. For example, the computer program **AT-BLAST** (available at no cost from the publicly accessible portion of the GSA web site www.oca.gsa.gov) may be used. This program, written by Applied Research Associates, implements the standard Kingery-Bulmash airblast equations that are also used in most Defense Department technical manuals. Alternatively, tables of pre-determined shock parameters may be used to estimate blast pressure and impulse. Tables 4 through 7 provide airblast parameters for 50, 100, 500 and 1000 lb TNT detonations at various standoff distances. If a shock wave impinges on a rigid surface oriented at an angle to the direction of propagation of the wave, a “reflected pressure” is instantly developed on the surface, and the pressure is raised to a value in excess of the “incident pressure” as illustrated in the figure.

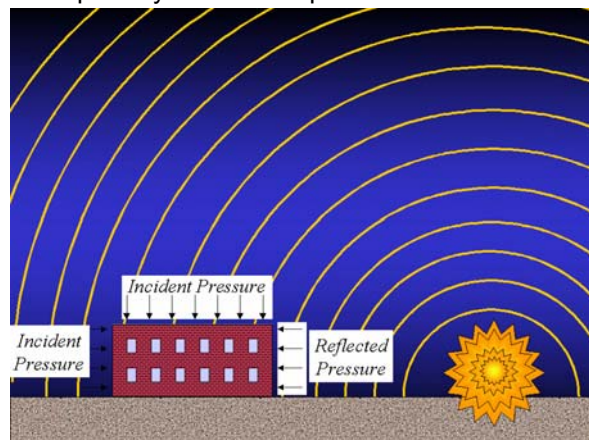

Table 4. Airblast parameters for 50-lb TNT detonation.

| 50 lb TNT | 20 ft | 50 ft | 75 ft | 100 ft | 200 ft | 300 ft |
|-------------------------------|-------|-------|-------|--------|--------|--------|
| Peak reflected pressure (psi) | 122.8 | 12.6 | 6.3 | 4.1 | 1.6 | 0.9 |
| Reflected impulse (psi-msec) | 136.5 | 47.5 | 30.6 | 22.5 | 10.9 | 7.1 |
| Peak incident pressure (psi) | 34.75 | 5.5 | 2.9 | 1.9 | 0.8 | 0.5 |
| Incident impulse (psi-msec) | 51.46 | 22.0 | 15.6 | 11.9 | 6.1 | 4.0 |

Table 5. Airblast parameters for 100-lb TNT detonation.

| 100 lb TNT | 20 ft | 50 ft | 75 ft | 100 ft | 200 ft | 300 ft |
|-------------------------------|-------|-------|-------|--------|--------|--------|
| Peak reflected pressure (psi) | 246.7 | 20.3 | 9.2 | 5.8 | 2.2 | 1.3 |
| Reflected impulse (psi-msec) | 228.5 | 77.4 | 49.4 | 36.3 | 17.5 | 11.4 |
| Peak incident pressure (psi) | 59.1 | 8.3 | 4.1 | 2.7 | 1.1 | 0.6 |
| Incident impulse (psi-msec) | 80.9 | 35.2 | 24.5 | 18.7 | 9.6 | 6.4 |

Table 6. Airblast parameters for 500-lb TNT detonation.

| 500 lb TNT | 20 ft | 50 ft | 75 ft | 100 ft | 200 ft | 300 ft |
|-------------------------------|--------|-------|-------|--------|--------|--------|
| Peak reflected pressure (psi) | 1182.6 | 79.5 | 27.4 | 14.6 | 4.6 | 2.6 |
| Reflected impulse (psi-msec) | 783.0 | 246.0 | 153.5 | 111.1 | 52.5 | 34.3 |
| Peak incident pressure (psi) | 197.0 | 24.9 | 10.7 | 6.3 | 2.1 | 1.3 |
| Incident impulse (psi-msec) | 209.1 | 96.6 | 67.5 | 52.4 | 27.4 | 18.5 |

Table 7. Airblast parameters for 1000-lb TNT detonation.

| 1000 lb TNT | 20 ft | 50 ft | 75 ft | 100 ft | 200 ft | 300 ft |
|-------------------------------|--------|-------|-------|--------|--------|--------|
| Peak reflected pressure (psi) | 2133.7 | 157.1 | 49.0 | 24.0 | 6.5 | 3.6 |
| Reflected impulse (psi-msec) | 1354.0 | 409.6 | 252.4 | 181.3 | 84.6 | 55.0 |
| Peak incident pressure (psi) | 314.7 | 42.0 | 17.1 | 9.6 | 3.0 | 1.7 |
| Incident impulse (psi-msec) | 222.8 | 150.0 | 104.1 | 81.0 | 43.1 | 29.2 |

In any bombing attack, there will be a level of risk to the occupants. This risk can be reduced through a combination of increasing standoff, structural hardening and other hazard mitigation techniques. Given an attack, there are three basic types of effects that the occupants may experience. These are:

- Primary Effects: Primary effects include the human body's response to direct blast loadings. These can be the result of exterior or interior detonations, which produce reflected, incident, and

possibly gas pressure loadings. The blast forces produced directly interact with the occupants causing injury or possibly death.

- Secondary Effects: Secondary effects include fragment and debris impacts. Heavy and/or high velocity fragments and debris interact with the occupants of the facility causing injury or possibly death.
- Tertiary Effects: Tertiary effects include loss of balance and subsequent impact of the person into his/her surroundings due to the passing blast wave or violent movement of a supporting structure.

The debris generated, or the collapse of structures produced, during an explosive attack causes the majority of injuries and death in a bombing event. As an example, over 5,000 people were injured by flying glass and debris in the bombings of two American embassies in Africa in 1998. The types of injuries that occurred included deep lacerations, eye injuries, etc. Approximately 90 people were blinded in the attack on the US embassy in Kenya.

Hazardous glass fragments are undeniably a major source of injury and/or death in an explosive attack. A total of 759 persons sustained injuries in the bombing of the A.P Murrah Federal Building. Of these, 319 were inside the target building and 440 were outside or in neighboring buildings. Among 405 injured persons who responded to a survivor survey taken by the Oklahoma State Department of Health, 266 people, 66% of those responding, attributed their injuries to flying glass or falling on broken glass. Actual data on the percent of people killed by impact with glass or wall fragments is limited. However, according to a database created by the Injury Prevention Service of the Oklahoma State Department of Health using information from the explosive attack on the Murrah Building, a little over 5% of the people injured from hazardous glass and wall fragments died. Also, from the same database, 10% of those exposed to high hazard glass or wall fragments suffered serious injury with permanent disabilities and 85% sustained serious, but recoverable injuries. Injury from glass breakage is not limited to the targeted facility. There was widespread glass breakage for more than a mile from the Murrah Building.

The majority of deaths in the Oklahoma City bombing on April 19, 1995 were due to the collapsing structure and associated debris. Data gathered by the Oklahoma Department of Health clearly shows that the majority of the fatalities occurred in or near the collapsed portions of the building. Even though the attack mode was significantly different, the same is true for the majority of the victims in the World Trade Center attack on September 11, 2001 – most died from debris impacts and the collapse of the structures.

In order to avoid massive casualties like those observed in the Oklahoma City bombing, progressive collapse must be avoided. In order to assess existing structures and design new ones to reduce the potential for progressive collapse, the GSA sponsored research in this area. From this work, an electronic, interactive tool, "Progressive Collapse Analysis and Design Guidelines for New Federal Office Buildings and Major Modernization Projects,"¹⁰ was developed. This document offers the user assistance in preventing progressive collapse. It includes

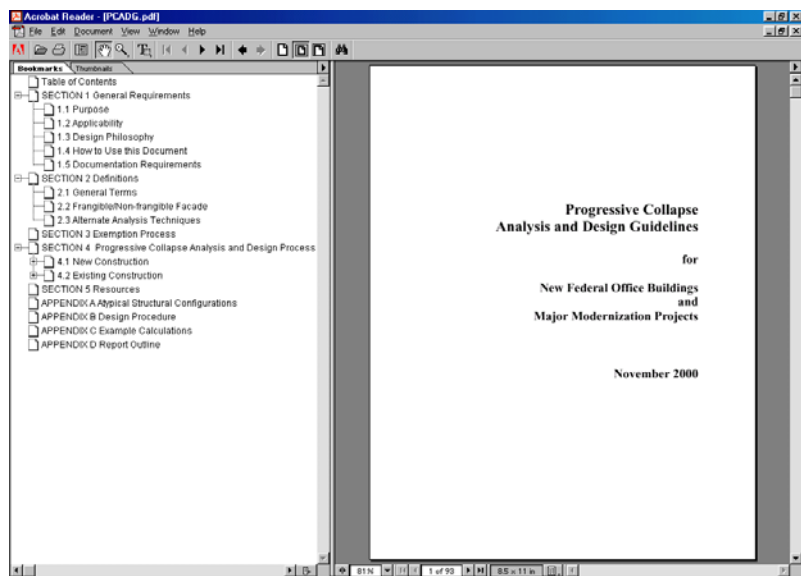

¹⁰ US General Services Administration, "Progressive Collapse Analysis and Design Guidelines for New Federal Office Buildings and Major Modernization Projects," Washington, DC, Central Office of the GSA, November 2000.

computer aided interactive utility programs to facilitate the exemption process and other calculations.

In developing the standard methodology for preventing progressive collapse, GSA took a forward-looking approach that should facilitate future implementation of the requirements. Progressive collapse is a technical issue that can be treated through direct design methods that are threat independent and hence multi-hazard in nature. The research conducted by GSA successfully showed that anti-progressive collapse design could be treated as independent of the actual threat. Since the objective is to arrest collapse once it starts (not to prevent damage due to a specific blast load or other extreme, abnormal load), the procedures for introducing progressive collapse prevention can be based upon methods and technologies that are widely used and available in the A/E community. The goal was to develop an adequate method that any competent structural engineering firm could follow without special expertise in blast or dynamics. Developed in this way, only the most special facilities require the attention of highly qualified blast specialists in the area of preventing progressive collapse.

Other structural retrofits and designs to resist blast generally require the skills of specialists in the field of blast consulting and structural dynamics. This is necessary due to the complex temporal and spatial variation of the extremely large forces acting over very short durations in a blast event. Typical structural retrofits and new design options include structural hardening, providing defended standoff distance, and providing redundancy or ductility. Specific applications include the use of conventional and composite materials, the use of innovative connection details, and the introduction of integral barrier systems. Typically, blast design must consider the walls, the roof system (slabs, beams, etc.), the structural framing (columns, shear walls, etc.), the windows, and the critical contents of facilities (computer centers, sensitive equipment, life safety utilities such as emergency water, power, etc.).

Blast Resistant and Hazard Mitigating Window Technologies

Another method of reducing injury and/or death is by mitigating the hazards from flying glass. The first step is to ensure that the window system design is balanced. The glazing, frames, and anchorage must all be able to survive the blast loading for the overall system to provide adequate protection. If any one part of the system fails, then the entire system fails. Similarly, the supporting wall must be able to handle the loads imparted into it by the window system. If the window system has a higher capacity than the supporting wall, when the wall fails the entire window system may be blown into the facility.

The United States General Services Administration has developed a method of evaluating the protection offered by various window configurations. This National Standard is similar to the rating schemes used by the British. Five performance conditions are used to indicate the location of fragments and/or shards after failure. The performance conditions are defined in the figure below.

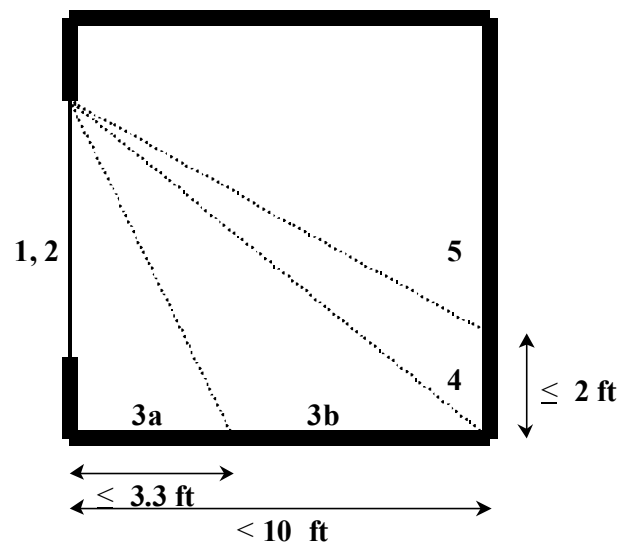

Table 8: GSA/ISC protection levels for glazing response to blast.

| Performance Condition | Protection Level | Hazard Level | Description of Window Glazing Response |
|-----------------------|------------------|--------------|--|
| 1 | Safe | None | Glass does not break. No visible damage to glazing or frame. |
| 2 | Very High | None | Glass cracks but is retained by the frame. Dusting or very small fragments near sill or on floor acceptable. |
| 3a | High | Very Low | Glass cracks. Fragments enter space and land on floor no further than 3.3 ft from the window. |
| 3b | High | Low | Glass cracks. Fragments enter space and land on floor no further than 10 ft from the window. |
| 4 | Medium | Medium | Glass cracks. Fragments enter space and land on floor and impact a vertical witness panel at a distance of no more than 10 ft from the window at a height no greater than 2 ft above the floor. |
| 5 | Low | High | Glass cracks and window system fails catastrophically. Fragments enter space impacting a vertical witness panel at a distance of no more than 10 ft from the window at a height greater than 2 ft above the floor. |

There are several options for increasing the capacity and/or reducing the hazards from the glazing portion of a window system. These include selecting an appropriate type of glass, applying security window film, installing blast curtains/shields, using laminated glass and/or a combination of these technologies.

Types of glass include:

- Plain float annealed glass is the most common glass type used in commercial construction. It has an ultimate design stress of 4000 psi and is the most hazardous.
- Heat strengthened glass is partially tempered which increases the ultimate design stress to 7600 psi. It gives a higher strength and slightly reduces hazard.
- Thermally tempered glass is fully tempered glass and this increases the ultimate stress to 16000 psi. It fails in small cube shaped fragments that are the least hazardous.

Tests have shown that the application of security window film on the interior glazing surface can significantly reduce hazard. Security windows film is typically 4, 6, 7, 8, or 11 mils (1/1000th of an inch) thick. There are four basic methods for applying this film. These are illustrated and explained below.

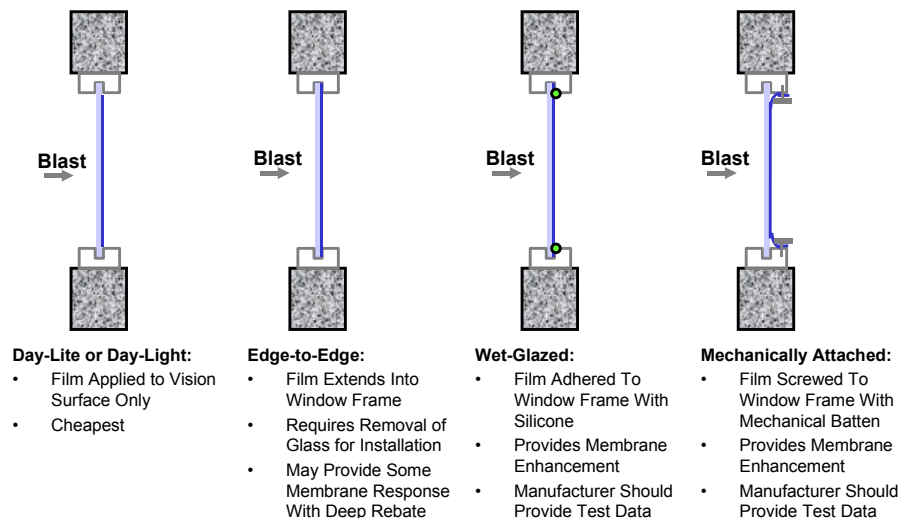



In order to obtain reliable and accurate test data for analytic model development and to evaluate window system and glass fragment hazard mitigation products, the GSA established a standard method for testing windows exposed to blast pressure. The most recent version of this standard was published in January 2003. Manufacturers that wish to have their products used in GSA facilities must test their products using the GSA standard test method as quality of these products can vary significantly from manufacturer to manufacturer. As a general rule, products that have been specifically engineered to perform well in blast environments perform much better than those products that have undergone limited or no research and development in this area. Using the GSA test standards, numerous window tests have been conducted by GSA and private companies since 1996. This test standard and its accompanying implementation memorandum may be downloaded from the publicly accessible portion of the GSA's web site www.oca.gsa.gov.

Blast curtains and shields can also be used to mitigate the hazards from flying glass. The curtains and shields do not stop the window from breaking, but they are designed to catch and trap the glass shards before they can be propelled into the room. The figures below and to the right show a blast curtain and a blast shield in action. As can be seen, the curtain and the shield trap large amounts of glass fragments and debris. Shields and curtains are most effective when used in conjunction with security window film.



Blast Curtain pre- and post-explosion.



Blast Shield deploying under a blast load catches fragments and debris.

Tests have also shown that laminated glass can be engineered to provide very high levels of protection at blast pressure/impulse levels even greater than blast curtains and/or films. The following figures show a series of pictures that depict the response of plain annealed glass to blast loads, the same type of glass with security window film installed, and laminated glass subjected to blast loads. It is evident that the unprotected annealed glass fails in a very hazardous manner (GSA Condition 5). The window with the

film breaks, but is retained in the frame by the security window film (GSA Condition 3). The laminated window also breaks, but holds together and stays in the frame (GSA Condition 2).

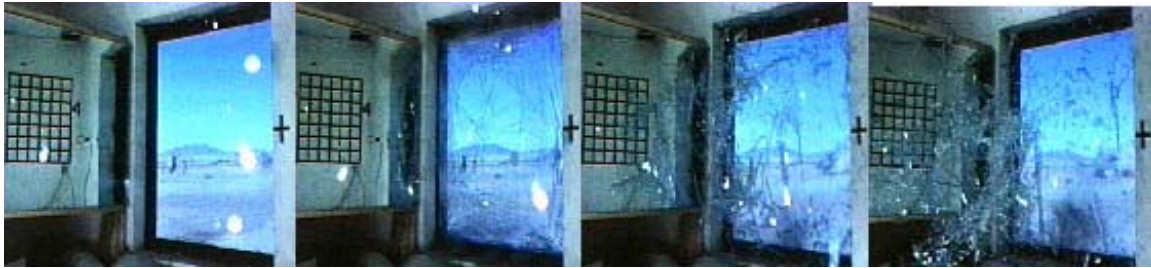

Unprotected annealed glass exposed to blast pressures (condition 5).



Security window film applied to annealed glass exposed to blast pressures (condition 3).



Laminated window exposed to blast pressures (condition 2).

Test data for dozens of window types are available on the publicly accessible portion of the GSA's website www.oca.gsa.gov. The data is available in tabular format as well as streaming video of the results. An example is shown to the right.

GSA Test Series 4 - Microsoft Internet Explorer

Address: http://www.oca.gsa.gov/explosive_testing/gsa_test_series4_june_4.php?real=yes

GSA OFFICE OF THE CHIEF ARCHITECT
U.S. General Services Administration

Home | Website Permissions | Contacts | 508 Compliance | Printer Friendly | Plug-ins

GSA Test Series 4

June 4 - June 6, 2002

| Specimen | Description | Measured Pressure (psi) | Measured Impulse (psi-msec) | GSA Performance Condition | Pictures |
|----------|---------------------------------|-------------------------|-----------------------------|---------------------------|----------|
| Test 1 | 1/4" monolithic AG, butt-glazed | 5.52 | 35.87 | 5 | |
| Test 2 | 1/4" laminated AG, butt-glazed | 5.02 | 35.73 | 3b | |

Applied Research Associates, Inc. under sponsorship from the GSA created the National Standard for predicting glazing response to blast (***WINGARD- WINDOW Glazing Analysis Response & Design***). **WINGARD** is available to those in and out of Government who have a need-to-know from the website www.oca.gsa.gov. For those who are not authorized to obtain direct access to **WINGARD**, there are a number of qualified blast consulting firms who may provide assistance.

WINGARD is capable of predicting the response of many window types subjected to blast forces. These include untreated windows, monolithic windows, insulating windows, windows with four-sided and two-sided (butt-glazed) frames, windows with security film and laminated glass. Window film options include daylight film, wet-glazed film and mechanically attached film in 2- or 4-sided installations. Laminated glass options include dry-glazed and wet-glazed installations. An example of **WINGARD** usage is illustrated in the following figures:

Choose Units:

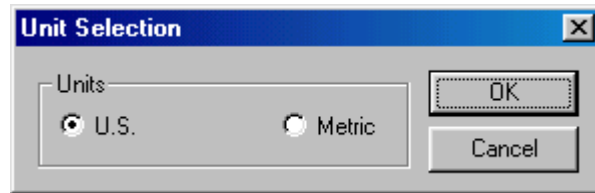

Input Blast Loads:

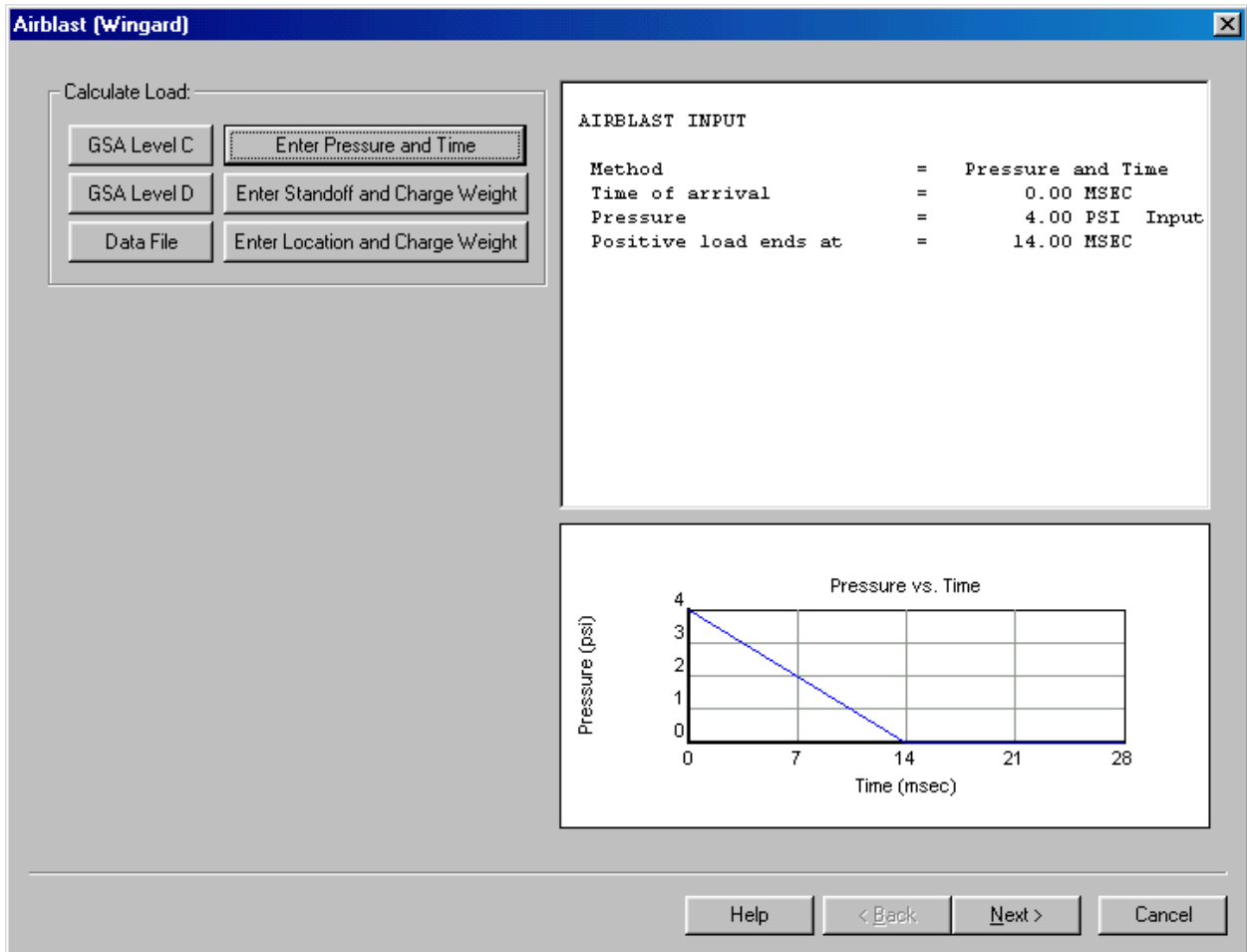

Define the Window Geometry:

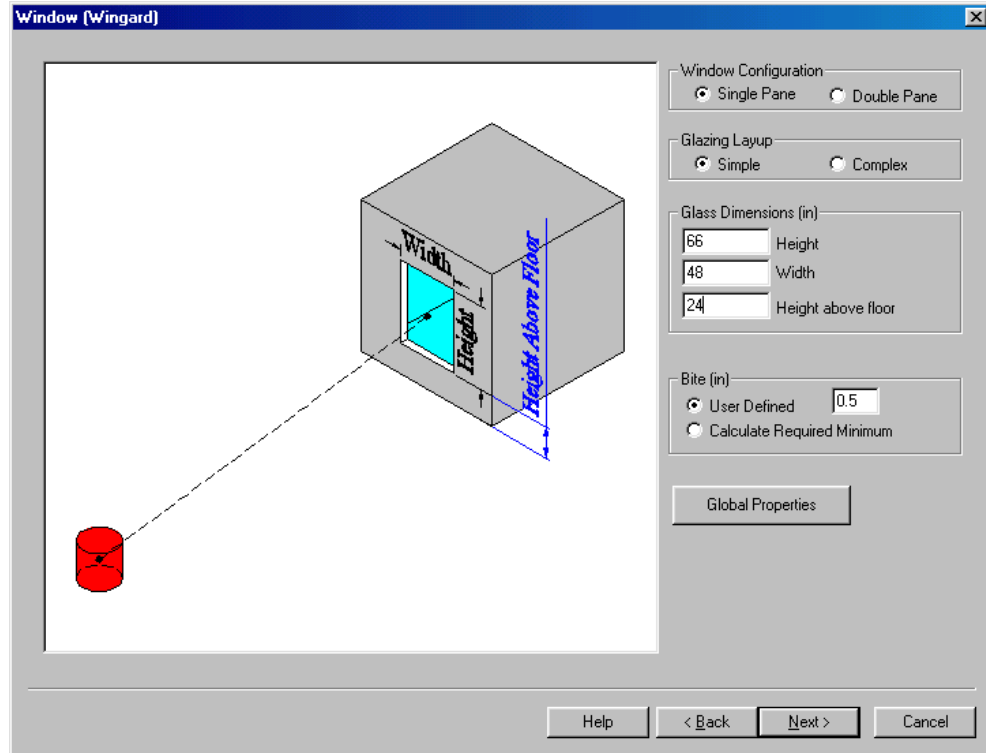

Define the Window Glazing and Treatment:

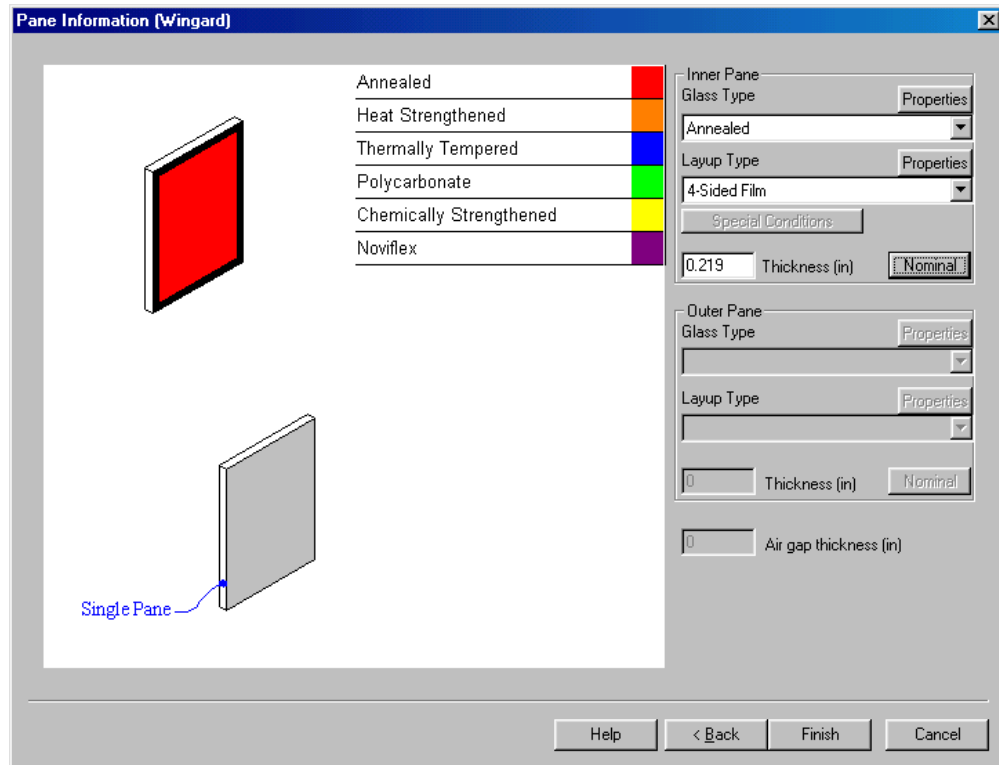

Calculate the Results:

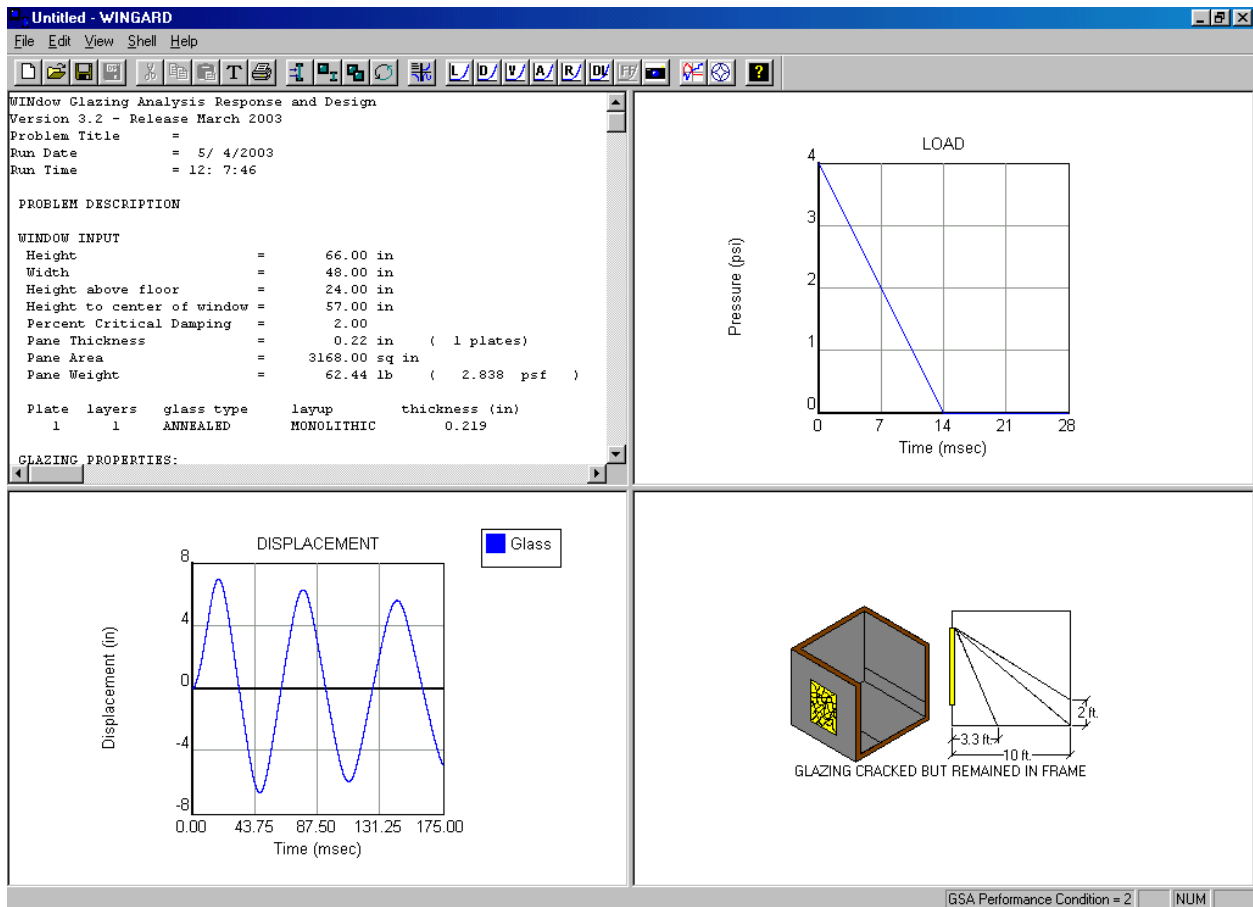

Security window films can significantly reduce the hazards posed by glass shards produced in a bombing event. This is illustrated with **WINGARD**. **WINGARD** was used to analyze a 48 by 66 in. window with a sill height of 2 ft above the floor. The maximum bomb size that the window could withstand while producing a GSA condition of 3b or lower was determined as a function of standoff distance. Calculations were run for four separate glazing types: 1) ¼ in. thick monolithic annealed glass with no treatments; 2) ¼ in. thick monolithic annealed glass with a 7 mil thick daylight installed security window film; 3) ¼ in. thick monolithic annealed glass with a 4 sided wet glazed, 7 mil thick film; and 4) ¼ in. thick monolithic annealed glass with a 4 sided mechanically attached, 7 mil thick film. A figure summarizing the results is shown on the following page.

Note in the figure that the bomb size for the window to sustain a 3b condition increases with increasing standoff distance. This is due to the fact the pressure and impulse from the explosion decrease with distance. Next, note that all of the film applications increase the amount of explosive that the windows can sustain while maintaining the 3b condition. For example, at a standoff of 300 ft in this example, the unprotected window will have 3b condition when exposed to less than 150 lb of TNT, whereas the window treated with a mechanically attached film has a 3b condition when exposed to over 1200 lb of TNT. Hence, the window films increase the ability of the windows to sustain blast loads in a controlled manner (i.e., they reduce vulnerability and risk to occupants). Note that in the example shown, the mechanically attached window film provides the greatest level of protection and the daylight-installed film provides the least.

**Maximum Explosive Charge Size (lb TNT) vs Standoff
Distance for a Medium Level of Protection
(ISC Level 3b or lower)
48 by 66 in. Sill at 24 in. Above Floor**

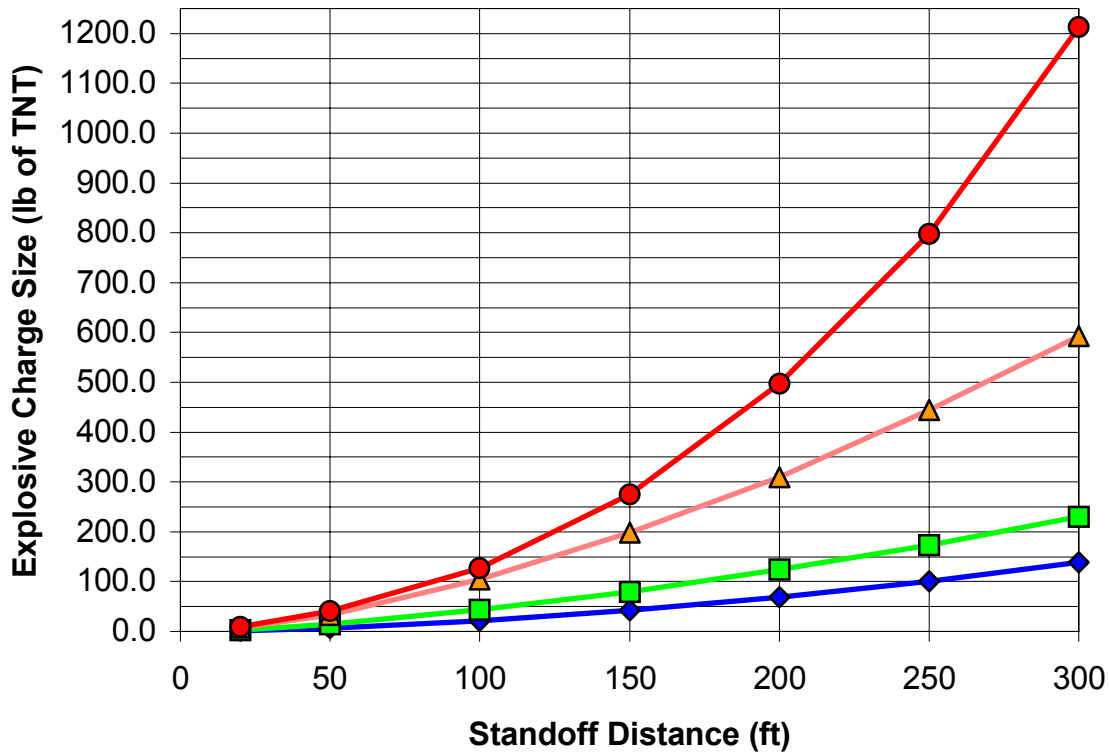

- ◆ 1/4 in. thick Annealed Glass 1/2 in. bite
- Add 7 mil thick day-light film
- ▲ Add 4 sided wet glazed 7 mil security film - 1/2 in. bead into frame bite
- Add 4 sided mechanically attached 7 mil security film

Many other new technologies are under-development to reduce the hazards from a bombing event. These innovative and cost-effective products and procedures will significantly enhance our ability to protect people. It is essential that a blast and security consultant be included in the earliest stages of project design. The GSA and all agencies that are signatory to the ISC Security Criteria now mandate this for Medium and Higher security level buildings. The inclusion of these specialists early in the design facilitates providing the desired levels of protection while minimizing the impact on architecture and cost.

CONTACT: Joseph L. Smith
 Vice President / Director, Security Consulting Services
 Applied Research Associates, Inc.
 119 Monument Place
 Vicksburg, MS 39180
 Phone: 601-638-5401 Fax: 601-634-0631 or Email: jsmith@ara.com

ABOUT THE AUTHOR:

Mr. Joseph L. Smith is a nationally known security and blast consultant with 22 years of experience in the areas of security engineering and explosion effects from conventional, nuclear and improvised (terrorist) explosions. He holds bachelors and master of science degrees in civil engineering from the United States Air Force Academy and Columbia University.

He has played a significant role in the U.S. response to the threat of terrorism. Most recently, he has assisted in the development of the GSA Security Criteria, the Interagency Security Criteria and the FAA Security Order 1600.69. In addition, he has led development teams in the creation of new technology and programs such as **WINGARD** (**W**INdow **G**lazing **A**nalysis **R**esponse & **D**esign) and **STANDGARD** (**S**TANdard **G**SA **A**ssessment **R**eporter & **D**atabase) for the GSA as well as **WINLAC** for the State Dept. These computer programs are recognized national standards for determining hazards from windows in explosions and for performing vulnerability assessments. Mr. Smith has also led teams in the development of new national progressive collapse guidelines, and has performed large scale explosive testing on numerous products and specimens.

Mr. Smith has directed 56 airport blast analyses and assessments since 9/11/2001, and is the patent holder of the Hardened Baggage Container, developed in response to the downing of Pan Am 103. His teams have provided security and protection services for many US icons and symbols including: the Liberty Bell, the Statue of Liberty, the Washington Monument, the Whitehouse complex, the Lincoln and Jefferson Memorials, the Smithsonian Institution, and the National Archives vaults that secure the Constitution, the Declaration of Independence, and the Bill of Rights, and many others.

Mr. Smith is a well-known speaker. He has presented at: the American Society of Industrial Security (ASIS) National Seminars in 1997, 1998, 1999, 2000, 2001, 2002 and 2003; the ASIS PacRim Conferences in 1998 and 2001; the GlassWeek 2000 National Conference; the S2K Security Conference; several Protective Glazing Council Seminar and Exhibits; the International Symposium on the Interaction of the Effects of Munitions with Structures; and numerous other presentations.

Mr. Smith is the author of over 300 technical papers and published works. He is a member of the American Society of Civil Engineers, the Society of American Military Engineers and the American Society of Industrial Security. He serves on the board of directors for the Protective Glazing Council and acts as a technical advisor to the Protecting People First Foundation.

REPRODUCTION OF THIS PAPER:

This paper is copyrighted by Applied Research Associates, Inc. Permission is granted to the AIMCAL Window Film Committee to distribute this paper via their official web site, by email and other mailings for the purposes of supporting the efforts of the AIMCAL Window Film Committee. Permission is granted to those who download or receive this paper to print and otherwise use this paper for personal use and reference. The paper may be used by the AIMCAL Window Film Committee and its members for educational purposes and for making presentations to clients and buyers of protective glazing products. The AIMCAL Window Film Committee may through its association with the IWFA also allow the IWFA to also use this paper for educational purposes. Any other use, including but not limited to re-distribution and/or use in commercial or advertising purposes is not allowed. Please contact the author for additional permission.



Call 866-933-3456 for a professional assessment or email us at: support@windowfilmdepot.com