

APPROVAL REPORT

3M™ SCOTCHSHIELD™ ULTRAFLEX WINDSTORM GLAZING PROTECTION SYSTEM FOR NEW AND RETROFIT GLAZING SYSTEMS

Prepared For:

THE 3M COMPANY
SPECIFIED CONSTRUCTION PRODUCTS
DEPARTMENT
3M CENTER 225-4S
SAINT PAUL, M N 55144

1D3A9.AM
Class 4350
Date: January 31, 2000

FACTORY MUTUAL 



Call 866-933-3456 for a professional assessment or email us at: support@windowfilmdepot.com

Factory Mutual Research
1151 Boston-Providence
Turnpike
P.O. Box 9102
Norwood, MA
02062

1D3A9.AM
(4350)

January 31, 2000

3M™ SCOTCHSHIELD™ ULTRAFLEX
WINDSTORM GLAZING PROTECTION SYSTEM
FOR NEW AND RETROFIT GLAZING SYSTEMS

From

THE 3M COMPANY
SPECIFIED CONSTRUCTION PRODUCTS DEPARTMENT
3M CENTER 225-4S
SAINT PAUL, MN 55144

I INTRODUCTION

- 1.1 The 3M Company submitted their 3M™ Scotchshield™ Ultraflex Windstorm Glazing Protection System for new and retrofit window systems to determine if it meets the Factory Mutual Research Standard 4350 (1995) Approval requirements for Windstorm Resistant Fenestration.
- 1.2 The examination included testing for static wind pressure resistance, impact resistance from windborne debris, cyclic wind pressure resistance and water leakage resistance testing.
- 1.3 Tests and in-plant audit inspections of the manufacturing facilities indicate that the 3M™ Scotchshield™ Ultraflex Windstorm Glazing Protection System as tested meets the Factory Mutual Research Approval Standard 4350 (1995) requirements when installed as specified in the CONCLUSIONS of this report.
 - 1.3.1 Factory Mutual Research Approval Standard 4350 is in draft form at the time of this report. The draft is based on other test methods currently in use by various jurisdictions, principally the Dade County and Southern Florida Building Codes. The test procedures and criteria may be changed in the future when the final version of the Approval Standard is published.
- 1.4 Tests were conducted at Hurricane Engineering & Testing Inc. in Miami, FL. A representative of Factory Mutual Research witnessed the manufacturing of the safety and security window film, and the application of the window film to the test specimens.

- 1.5 As a manufacturer of a Factory Mutual Research Approved product, the companies that manufacture the components of the Approved product will be subjected to Factory Mutual Research's follow-up Facilities and Procedures Audit inspection program. The purpose of the inspections is to satisfy Factory Mutual Research that the manufacturers are using sufficient quality controls to assure that continued production of the components are equivalent to those originally tested and Approved.

II MATERIALS TESTED

- 2.1 The 3M Company 3M™ Scotchshield™ Ultraflex Windstorm Glazing Protection System consists of the following components:
- 2.1.1 The safety and security window film is identified as 3M™ Scotchshield™ Ultra Safety and Security Window Film, Ultra 400 Series, manufactured by The 3M Company. This safety and security grade window film consists of 2 layers of an optically clear micro layered polyester film, nominal thickness of 2 mil [0.002 in. (0.051 mm)] each layer, laminated together with an acrylic pressure sensitive adhesive. Each layer is made up of 13 micro-thin layers of film. One side of the window film is coated with a scratch-resistant coating, and the other side is coated with an acrylic pressure sensitive adhesive and a release liner. The laminated layers shall have an average nominal thickness of 4 mil [0.004 in. (0.102 mm)] excluding adhesive, release liner and scratch resistant coating. The 3M™ Scotchshield™ Ultra Safety and Security Window Film is available in four tinted versions: Type SCLARL400 (clear), Type S20SIAR400 (silver), Type S35NEAR400 (neutral), or Type S50NEAR400 (It. neutral), in roll widths up to 60 in. (1.52 m) wide. It shall be applied to clean bladed glass with a squeegee and sealed to the perimeter of the window frames with the 3M™ Scotchshield™ Ultraflex Windstorm Glazing Protection System.
- 2.1.2 The window frame shall be a max 78 in. (1.98 m) x 50 in. (1.27 m) specimen with a maximum clear opening of 74-1/2 in. (1.89 m) x 46-1/2 in. (1.18 m). The max glazing size shall be 75-1/16 in. (1.91 m) x 47-1/16 in. (1.20 m). The frame shall be constructed from 6063-T5-aluminum alloy. Frame components shall be sized as detailed in Appendix A. The frame is fastened into the head, sill and jambs with 1/4 in. (6.4 mm) screws or anchors spaced 6 in. (152 mm) o.c. and 3 in. (76 mm) max in the vertical and 4 in. (102 mm) max in the horizontal direction at each corner. The frame was 1-3/4 in. (44 mm) wide x 4-1/2 in. (114 mm) deep and was designated as a type MK-1, series 4500, manufactured by Arch Aluminum and Glass.
- 2.1.3 The glazing material shall be min 3/16-in. (4.8 mm) thick clear tempered glass, and shall bear markings indicating that it is clear tempered glass such as "3/16 CLT" or similar marking indicating that the glass has been fully tempered. The glazing is installed in the window frame using a continuous vinyl gasket along the exterior perimeter of the window. See Appendix B for details.
- 2.1.4 The 3M™ Ultraflex Window System utilizes Dow Corning 995 Silicone Structural Adhesive which is applied in a bead around the perimeter of the glass/frame interface on the inside of the window frame. The bead is installed such that there is a min 3/8-in. (10 mm) overlap onto both the frame and the film covered glazing.
- 2.1.1 Masking tape is used to form an adhesive channel on the film to allow a uniform adhesive bead to be applied. It is identified as 3M™ Scotch™ brand Safe-Release™ Masking Tape, and is manufactured by The 3M Company. The tape is 1 in. (25 mm) wide.

- 2.1.6 Masking tape is used to form an adhesive channel on the frame to allow a uniform adhesive bead to be applied. It is identified as 3M™ Scotch™ brand Long-Mask™ Blue Masking Tape, and is manufactured by The 3M Company. The tape is 1 in. (25 mm) wide.
- 2.1.7 The open cell polyurethane foam backer rod is 5/8 in. (16 mm) in diameter. The backer rod is used when the inside gasket is removed to provide a bottom surface for the adhesive. It is manufactured by Backer Rod Manufacturing Co., Inc.
- 2.2 The proprietary formulations and specifications for the above components are on file at Factory Mutual Research.

III

TESTS AND PROCEDURES

- 3.1 Tests conducted were as required by Factory Mutual Research Draft Standard 4350 (1995) -Approval requirements for Windstorm Resistant Fenestrations.
- 3.2 **Factory Mutual Research Impact Resistance Tests**
- 3.2.1 The Factory Mutual Research impact resistance tests were conducted on three samples to determine the ability of the assembly to resist damage from flying debris. The test procedures involved small missile tests which simulates exposure to fenestration at high building elevations.
- 3.2.2 The impact resistance tests utilized a small missile cannon, which consisted of a 1-in. (25-mm) internal diameter by 4-ft (914-mm) long pipe mounted on a support frame. Compressed air is supplied to the cannon and monitored by a pressure gauge. A remote firing device and valve is utilized to fire the missiles. The small missiles shall consist of ten (10) 2-gram steel ball bearings.
- 3.2.3 A timing system to measure the speed of the missiles consists of two photoelectric sensors and an electronic timer. The sensors are located 2 ft (610 mm) from each other. The electronic timer has a response time of 0.10 milliseconds. The timer shall be activated when a missile passes trough the first sensor and deactivated when the missile travels through the second sensor.
- 3.2.4 When ready for testing, the air cannon shall be positioned so that each of the three test specimens received a series of three small missiles. Each series shall consist of ten small missile impacts. fired simultaneously. The end of the cannon shall be located at an appropriate distance from the test Panel such that the missiles are distributed over a maximum spread of 2 ft² (0.2 M²) area of the test specimen. The series of impacts shall be located at the center of the test specimen. along the edge of the center of the long dimension of the test specimen, and at one corner of the test specimen.
- 3.2.5 The small missiles shall impact the surface of the test specimen with a speed of 130 ft/s - 132 ft/s (39.6 m/s - 40.2 m/s) which is equivalent to approximately 90 miles per hour.
- 3.2.6 The speed of the missiles shall be computed by dividing the distance between the sensors by the measured time. Only one small missile per firing needs to be monitored for speed.

- 3.2.7 After each missile impact the test specimen shall be examined to determine if any missiles have penetrated the system. No penetration or through openings in the system are allowed as a result of the small missile impact test.

3.3

Factory Mutual Research Cyclic Wind Pressure Resistance Tests

- 3.3.1 Tests were conducted using a Cyclic Wind Pressure Resistance Test Apparatus to evaluate the ability of the system to withstand cyclic wind loads. During a severe wind event, exterior building components are subjected to a wide range of wind forces from sustained winds and wind gusts, both blowing in multiple directions. Because the components are also exposed to flying debris, the cyclic loads are applied on test specimens that have satisfactorily met the impact resistance requirements.
- 3.3.2 A cyclic load shall be applied to three test samples. Air shall be regulated and exhausted by valves controlled by pressure transducers. The loading schedule is shown below. Positive pressure direction is towards the interior of the assembly. Negative pressure direction is towards the exterior of the assembly. Each load cycle shall have a duration of 1 to 3 seconds.

<u>Loading Sequence</u>	<u>Pressure Range</u>	<u>Cycles</u>	<u>Pressure Direction</u>
1	0.2P - 0.5P	3500	Positive
2	0.0P - 0.6P	300	Positive
3	0.5P - 0.8P	600	Positive
4	0.3P - 1.0P	100	Positive
5	0.3P - 1.0P	50	Negative
6	0.5P - 0.8P	1050	Negative
7	0.0P - 0.5P	50	Negative
8	0.2P - 0.5P	3350	Negative

- 3.3.3 Between load sequences and after the final load sequence the test specimen shall be examined for the presence of separation between any components, cracks and openings.
- 3.3.4 The assemblies shall not exhibit any cracks longer than 5 in. (127 mm) through which air can pass or any openings through which a 3 in. (76 mm) diameter sphere can pass or be unable to withstand the applied pressures.

3.4

Factory Mutual Research Susceptibility to Water Leakage Test

- 3.4.1 A test was conducted using the a Wind Pressure Test Apparatus and Test Specimen Frame to assess the potential for water to penetrate the fenestration assembly.
- 3.4.2 Fenestration designed to prevent water from entering the building shall exhibit their water leakage resistance by not allowing any water from penetrating the assembly. Additionally, these fenestration after being subjected to the impact and cyclic loading tests shall not show any signs of water entry within 1 ft (0.3 m) from the interior face of the test specimen.
- 3.4.3 A water spray system having nozzles spaced on a uniform grid shall be located approximately 2 in. (51 mm) away from the test specimen. The spray nozzles shall be positioned to distribute water uniformly against the test specimen at a rate of 5 gal/ft²/hr (3.4 l/m²/Min).

3.4.4 During the exposure period and 15 minutes after the water spray has been turned off the interior side of the fenestration shall be observed for the presence of water leakage.

3.5 **Factory Mutual Research Static Wind Pressure Tests**

3.5.1 Tests were conducted using a Static Wind Pressure Apparatus to measure the wind resistance performance of the assembly. The objective of this test is to provide a realistic method of evaluating the static wind pressure resistance of an installed assembly and the individual components when applied within an installed assembly.

3.5.2 The method is designed to measure the stability of the assembly on its supports and to evaluate the ultimate strength of the individual components in the completed assembly under static conditions which simulate the loads imposed by wind forces on the building envelope.

3.5.3 The fenestration shall possess adequate physical properties to resist a specified minimum pressure without separating from supporting members; suffering permanent deformation, cracking, or fracturing of any component; or failing to resist the applied load.

3.5.4 A static load shall be applied to the test sample. Valves controlled by pressure transducers shall regulate air. The designated uniform static pressure is applied to the assembly and maintained for a duration of 60 seconds. The pressure is released and the opposite acting uniform static pressure is applied to the assembly and maintained for a duration of 60 seconds.

3.5.5 Between load sequences and after the final load sequence the test specimen shall be examined for separation from supporting members; permanent deformation, cracking, or fracturing of any component; or failing to resist the applied load.

3.6 **Weathering Resistance and Air Leakage Rate Tests** were not conducted as part of this examination.

IV **TEST SAMPLES**

4.1 Three 78 in. (1.98 m) x 50 in. (1.27 m) specimens were constructed. The components and sequence of installation were as follows:

4.1.1 A 78 in. (1.98 m) x 50 in. (1.27 m) overall size specimen was identified as being constructed from 3/16 in. (4.8 mm) thick clear tempered glass. The glass bore a label indicating 3/16 in. tempered glass, and bore a marking "3/16 CLT". The glazing size was 75 1/16 in. (1.91 m) x 47-1/16 in. (1.20 m), and the clear opening was 74-1/2 in. (1.89 m) x 46-1/2 in. (1.18 m) resulting in a 1/4 in. (6.4 mm) +/- 1/32 in. (0.8 mm) glass bite on all sides. The window frame was 1-3/4 in. (44 mm) wide x 4-1/2 in. (114 mm) deep and was identified as being constructed from 6063-T5 aluminum alloy. Each corner of the frame was butt joined and secured with two (2) #8 x 1-1/4 in. (32 mm) long self-drilling screws. The frame was secured into the head, sill and jambs of the test buck with 1/4 x 3 in. (6.4 x 102 mm) screws or anchors spaced 6 in. (152 mm) o.c. and 3 in. (76 mm) max in the vertical and 4 in. (102 mm) max in the horizontal direction in each corner. A wedge-in vinyl glazing gasket, size 9/16 x 7/16 in. (14 x 11 mm) was installed on the exterior perimeter of the specimen at the intersection of the glass and

the window frame. The same gasket was installed on the interior corner of each specimen, extending 3 in. (76 mm) from each corner in both directions. This was used to hold the glass in place. Foam backer rod was placed around the remainder of the interior perimeter. Refer to 111.1 of Appendix A.

4.1.2 The glazing was prepped by cleaning and blading the glass. The 3M™ Scotchshield™ Ultra Safety and Security Window Film. Type SCLARL400 was laminated to the glazing and a squeegee was used to set the film to the glazing. A water and soap combination was used as a slip solution. The film was applied such that it completely covered the glazing. A max 3/16-in. (4.8 mm) cutback was provided between the edge of the film and the edge of the glass around the perimeter of the assembly. Refer to III.1 of Appendix A.

4.1.3 The 3M Company 3M™ Ultraflex Window System was applied as follows: 3M™ Scotch™ brand Safe-Release™ Masking Tape was applied to the film covered glass 3/8 in. (10 mm) from the glass/frame interface around the perimeter of the sample on the inside of the window frame. 3M™ Scotch™ brand Long-Mask™ Blue Masking Tape was applied to the frame 3/8 in. (10 mm) from the glass/frame interface around the perimeter of the sample on the inside of the window frame. These tapes form an adhesive channel. Dow Corning 995 Silicone Structural Adhesive is applied into the channel formed by the tape. The bead is installed such that there is a min 3/8-in. (10-mm) overlap onto both the frame and the film covered glazing. The adhesive is smoothed with an appropriate tool to give a finished look. The tape is removed and the system is allowed to cure. Refer to III.1 of Appendix A. For further installation instructions, see Appendix B. All samples were identical.

4.2 The design of the window frame and glazing method used for these tests consists of a storefront framing system that was designed to use glazing gaskets on the exterior and interior of the glass. The system as tested had the interior-glazing gasket (with the exception of 3-in. [76-mm] long corner pieces) permanently removed prior to the application of the 3M™ Scotchshield™ Ultraflex Windstorm Glazing Protection System. The open cell polyurethane foam backer rod is used to replace the portion of the interior-glazing gasket, which was removed. As an alternative to removing the interior glazing gasket, smaller gaskets (1/2 in. [13 mm] or less) may be cut at a 45-degree angle so that the blade cuts down into the film-retaining channel. This will form an adhesive channel. Refer to III.1 of Appendix A.

RESULTS

5.1 Factory Mutual Research Impact Resistance Tests

5.1.1 Three separate samples were subjected to a series of small missile impact tests, each of which included ten (10) missiles impacting each specimen in three (3) different locations. The class in the specimens shattered upon impact but the missiles did not penetrate the assembly.

5.1.2 All three of the series of impacts utilized ten (10) 2-gram steel ball bearings.

5.2 Factory Mutual Research Cyclic Wind Pressure Resistance Tests

5.2.1 A- series of cyclic wind pressure tests were conducted on three separate samples after they had been subjected to the small missile impact tests. No cracks developed longer than 5 in. (127 mm) through which air can pass or through which a 3-in. (76-mm) diameter sphere can pass.

5.2.2 The design pressures used during the tests were +65 psf (+3.1 kPa) and -106 psf (-4.9 kPa).

5.3 **Factory Mutual Research Susceptibility to Water Leakage Test**

5.3.1 One susceptibility to water leakage test was conducted on a sample after the small missile impact test and the cyclic wind load resistance test.

5.3.2 The pressure was set at 10.0 psf (0.5 kPa) and the test was run for fifteen minutes. A minimal amount of leakage (approximately 1 fl. oz./min) was observed.

5.4 **Factory Mutual Research Static Wind Pressure Tests**

Static wind pressure tests were conducted on one (1) sample. The static pressures used were +98 psf (+4.5 kPa) and -159 psf (-7.4 kPa). The sample met all criteria for the duration of the test.

VI

CONCLUSIONS

6.1 Test results from this Factory Mutual Research Approval program indicate that the 3M™ Scotchshield™ Ultraflex Windstorm Glazing Protection System for new and retrofit window systems meets the Factory Mutual Research Approval Standard 4350 (1995) requirements for Windstorm Resistant Fenestration when installed as summarized below:

6.2 **New Installations**

The 3M™ Scotchshield™ Ultraflex Windstorm Glazing Protection System, produced by The 3M Company is approved for new installations, when installed as described:

6.2.1 **Window frame and glazing**

Max opening size:	24.0 ft ² (2.23 m ²) with the height of the opening not exceeding 74-1/2 in. (1.89 m) and the width of the opening not exceeding 46-1/2 in. (1.18 m).
Material:	Aluminum alloy 6063-T5.
Profile:	Components as shown in Appendix A.
Attachment:	1/4 in. (6.4 mm) screws or anchors spaced 6 in. (152 mm) o.c. and 3 in. (76 mm) max in the vertical and 4 in. (102 mm) max in the horizontal direction at each corner. Screws/anchors shall be compatible with the structural anchoring material (either steel or concrete) and shall be embedded into the structural surface to a min depth of 1-1/2 in. (38 mm).

- Glazing: Min 3/16 in. (4.8 mm) thick. clear, fully tempered glass bearing a marking such as "3/16 CLT" or similar marking indicating such. Contains vinyl gasketing along the entire exterior perimeter as shown in Appendix A. Sized to ensure a min glass bite of 1/4 in. (6.4 mm) +/- 1/32 in. (0.8 mm).
- Assembly: Shall be provided by the manufacturer as a complete unit.

6.2.2 **Safety and security window film**

3M™ Scotchshield™ Ultra Safety and Security Window Film, Ultra 400 Series, 4 mil [0.004 in. (0.102 mm)] thick. max 60-in. (1.52 m) wide. Applied to clean, bladed min 3/16 in. (4.8 mm) thick clear fully tempered glass in accordance with the manufacturers installation instructions and details as shown in Appendix B. Edges of film shall be provided with proper cutback for proper application of the 3M™ Scotchshield™ Ultraflex Windstorm Glazing Protection System. The window film shall be applied only to the interior surface of the window assembly.

6.2.3 **3M™Scotchshield™Ultraflex Windstorm Glazing Protection System** (See Appendix A):

Open cell polyurethane foam backer rod:	Backer rod used along the inside perimeter of the frame assembly to replace removed vinyl gasket.
3M™ Scotch™ brand Safe-Release™ Masking Tap	Tape used along perimeter of glass/frame interface to form an adhesive channel.
3m™ Scotch™ brand Long-Mask™ Blue Masking Tape	Tape used along perimeter of glass/frame interface to form an adhesive channel.
Dow Corning 995 Silicone Structural Adhesive	Adhesive used to bond film to frame.

- 6.2.3.1 The system above is installed in accordance with the manufacturer's instructions (see Appendix B) and as summarized below:
 - a) In a manufacturing setting, the aluminum glazing material (window frame) is cut to length. Anchoring holes are pre-drilled, the frames are assembled, labeled as Factory Mutual Research Approved, then transported to the job-site.
 - b) The assembled frames are placed in the rough openings, shimmed so they are square and plumb, and fastened as detailed above. A bead of silicone is run around each screw head. along each corner joint. and around the exterior perimeter of the frame. The glazing is installed and the snap on sill cover is put in place and the wedge-in gasket is installed on the exterior side of the glass, as well as in the corners of the interior side.

WINDSTORM TESTING

of the glass extending a min of 3-in. (76 mm) from each corner in both directions. Foam backer rod is placed around the remainder of the interior perimeter.

- b) The glazing is prepped by cleaning and blading the glass. Once dry, the safety and security window film is laminated to the interior of the glazing and a squeegee is used to set the film to the glazing. A water and soap combination is used as a slip solution. 3M™Scotch™ brand Safe-Release™ Masking Tape is applied to the film covered glass 3/8 in. (10 mm) from the glass/frame interface around the perimeter of the sample on the inside of the window frame. 3M™Scotch™ brand Long-Mask™ Blue Masking Tape is applied to the frame 3/8 in. (10 mm) from the glass/frame interface around the perimeter of the sample on the inside of the window frame. These tapes form an adhesive channel. Dow Corning 995 Silicone Structural Adhesive is applied into the channel formed by the tape. The bead is installed such that there is a min 3/8-in. (10 mm) overlap onto both the frame and the film covered glazing. The adhesive is smoothed with an appropriate tool to give a finished look. The tape is removed and the system is allowed to cure.

6.2.4 Design parameters

- 6.2.4.1 The assemblies may be installed on the exterior face or corners of buildings where small missile impact resistance is required and where design pressures are not expected to exceed (inward acting) +54 psf (2.5 kPa) or (outward acting) -88 psf (4.1 kPa).
- 6.2.4.2 For guidelines on determining anticipated pressure levels for specific locations, refer to FM Global Property Loss Prevention data Sheet 1-7.
- 6.2.4.3 The above design pressures incorporate a factor of safety of 1.2.

6.3 Retrofit Installations

The 3M Scotchshield™ Ultraflex Windstorm Glazing Protection System, produced by The 3M Company is approved for retrofit use over existing window units when installed as described:

6.3.1 Window frame and glazing

- Max opening size: 24.0 ft² (2.23 m²) with the height of the opening not exceeding 74-1/2 in. (1.89 m) and the width of the opening not exceeding 46-1/2 in. (1.18 m).
- Material: Steel or aluminum.
- Attachment: 1/4 in. (6.4 mm) screws or anchors spaced 6-in. (152-mm) o.c. and 3 in. (76 mm) max in the vertical and 4 in. (102 mm) max in the horizontal direction at each corner. Screws/anchors shall be compatible with the structural anchoring material (either steel or concrete) and shall be embedded into the structural surface to a min depth of 1-1/2 in. (38 mm).

Glazing: Min 3/16 in. (4.8 mm) thick. clear, fully tempered glass bearing a marking such as "3/16 CLT" or similar marking indicating such. Contains vinyl gasketing along the entire exterior perimeter as shown in Appendix A. Sized to ensure a min glass bite of 1/4 in. (6.4 mm) +/- 1/32 in. (0.8 mm).

6.3.2 **Safety and security window film** see Par. 6.2.2 above.

6.3.3 **3M™ Scotchshield™ Ultraflex Windstorm Glazing Protection System** (See Appendix A) installed in accordance with Par. 6.2.3 and 6.2.3.1 above and 6.3.3.1, 6.3.4, 6.3.4.1, 6.4.3.2, 6.3.5, 6.3.5.1, 6.3.5.2 and 6.3.5.3 below.

6.3.3.1 The design of the window frame and glazing method used for the glass being protected shall consist of a framing system that was designed to use glazing gaskets on both the exterior and interior of the glass. The existing system shall have the interior glazing gasket either permanently removed or trimmed in accordance with Par. 4.2 above prior to the application of the 3M Company 3M™Scotchshield™ Ultraflex Windstorm Glazing Protection System. Where the interior glazing gasket is permanently removed, foam backer rod is placed.

6.3.4 **Additional requirements** prior to retrofit installation of the safety and security window film and The 3M Company 3M™ Scotchshield™ Ultraflex Windstorm Glazing Protection System, an assessment of the existing window frame and it's securement to the building shall be conducted.

6.3.4.1 The larger of three (3) individual units or 5% of all existing units expected to receive the retrofit on any single building, shall be physically examined to determine the adequacy of the method used to secure the existing window frames to the building.

- a) If necessary, additional fasteners shall be installed such that all sides of the existing frame are secured with min 1/4 (6.4 mm) screws spaced max 6 in. (152 mm) o.c. along the head, sill and jambs and no further than 3 in. (76 mm) max in the vertical and 4 in. (102 mm) max in the horizontal direction at each corner.
- b) The appropriate type and length of fasteners are to be used for securement for the type structural member encountered (structural steel or concrete only) such that the resulting embedment shall be a min of 1.5 in. (38 mm).c) Wood framing members or hollow masonry units shall not be considered as a suitable structural material for securement of the existing window frames.

6.3.4.2 The adequacy of the frame to resist the design pressures shall also be determined. See Par. 6.3.5 and 6.4 for details.

6.3.5 Design parameters

- 6.3.5.1 The assemblies may be installed on the interior surface of windows located on the exterior face or corners of buildings where small missile impact resistance is required and where design pressures are not expected to exceed (inward acting) +54 psf (2.5 kPa) or (outward acting) -88 psf (4.1 kPa).
- a) The maximum design pressure of The 3M Company 3M™ Scotchshield™ Ultraflex Windstorm Glazing Protection System shall not exceed those shown above and shall be limited to the design pressure of the existing window frame.
 - b) The design pressure of the existing window frame shall be determined and certified by a registered Professional Engineer for the maximum positive and negative pressures the existing frame and its securement to the building can withstand.
 - c) The manufacturer shall maintain a permanent file containing the engineer's certification for each project.
- 6.3.5.2 For guidelines on determining anticipated pressure levels for specific locations, refer to FM Global Property Loss Prevention data Sheet 1-7.
- 6.3.5.3 The above design pressures incorporate a factor of safety of 1.2.

6.4 The 3M Company 3M™ Scotchshield™ Ultraflex Windstorm Glazing Protection System, when installed as described above, meets Factory Mutual Research Approval requirements for small missile impact resistance at the indicated pressure levels. When Approval is effective, these systems will be listed in the Factory Mutual Research Approval Guide.

6.4.1 These assemblies have been examined for small missile impact resistance, static and cyclic wind pressure resistance and water leakage resistance and are deemed capable of protecting the integrity of the building envelope during high wind events such as hurricanes.

6.4.2 These assemblies were not examined for weathering resistance or air leakage rates.

6.4.3 While these assemblies are expected to maintain the building envelope and prevent damage to the interior of the building and its contents from high winds, wind borne debris and water damage. depending on the severity of the event. these units may suffer permanent deformation or physical damage from the wind borne debris or wind pressures, necessitating the replacement of all or part of the system.

6.4.4 Each assembly should be visually examined for damage after each high wind event. Those showing signs of permanent deformation or physical damage shall be replaced in order to maintain their ability to protect the integrity of the building envelope.

6.5 The tested constructions meet the Factory Mutual Research Approval criteria and when Approval is effective will be listed in the Factory Mutual Research Approval Guide.

6.6 Approval is effective when the Approval Agreement (Factory Mutual Research Form L-15) is signed and received by Factory Mutual Research.

- 6.7 Continued approval will depend upon satisfactory field experience and periodic Quality Audit Inspections.

VII MARKING

- 7.1 Components of The 3M Company 3M™ Scotchshield™ Ultraflex Windstorm Glazing Protection System shall contain markings indicating Factory Mutual Research Approval in accordance with the following:

7.1.1 Each new window frame unit shall contain the Factory Mutual Research Approval mark. The mark shall be located along the jamb of the frame. The mark may be located such that it will not be visible after the unit is installed. The markings may consist of either an adhesive backed paper label or an embossment die that is punched onto each unit as indicated above. Markings denoting Factory Mutual Research Approval shall be applied by the manufacturer only within and on the premises of the Arch Aluminum & Glass L.C. manufacturing location at 10200 N.W. 67th Street, Tamarac, FL 33321 that is under the Factory Mutual Research Facilities and Procedures Audit Program.

7.1.2 Each package or wrapper of the 3M™ Scotchshield™ Ultra Safety and Security Window Film, Ultra 400 Series, 4 mil [0.004 in. (0.102 mm)] thick, manufactured by The 3M Company, shall contain the manufacturer's name and product trade name, the Factory Mutual Research Approval mark and the words "Subject to the conditions of Approval as a Hurricane Protection System when installed as described in the current edition of the Factory Mutual Research Approval Guide".

- 7.2 Markings denoting Factory Mutual Research Approval shall be applied by the manufacturer only within and on the premises of manufacturing locations that are under the Factory Mutual Research Facilities and Procedures Audit Program. Field labeling of the window frames or the attachment system shall not be permitted.

- 7.3 The manufacturer agrees that use of the Factory Mutual Research name or Approval Mark is subject to the conditions and limitations of the Factory Mutual Research approval. Such conditions and limitations must be included in all references to Factory Mutual Research Approval.

VIII MANUFACTURER'S RESPONSIBILITIES

- 8.1 To assure compliance with installation procedures in the field, the manufacturer shall supply to the installer such necessary instructions or assistance as required to produce the desired performance achieved in the tests.
- 8.2 The manufacturer shall notify the Factory Mutual Research of any planned change in the Approved product prior to general sale or distribution. All requests for changes shall be made and agreed to in writing, utilizing Factory Mutual Research Form 797, "Approved Product-Revision Report".

- 8.3 The manufacturer agrees that the use of the Factory Mutual Research name or Approval Mark is subject to the conditions and limitations of the Factory Mutual Research Approval. Such conditions and limitations must be included in all references to Factory Mutual Research Approval.
- 8.4 Continued Approval is based upon the manufacture of all components in accordance with this Approval Report, satisfactory field experience, and continued use of acceptable quality control procedures as determined by Facilities and Procedures Audits.

IX FACILITIES AND PROCEDURES AUDITS

- 9.1 Ongoing follow-up Facilities and Procedures Audits at the safety and security window film material manufacturing facility (The 3M Company, Knoxville, IA), the window frame for new construction manufacturing facility (The William L. Bonnell Company, Carthage, TN), the window frame manufacturing facility (Arch Aluminum & Glass L.C., Tamarac, FL), and the adhesive manufacturing facility (Dow Corning Corporation, Elizabethtown, KY) have indicated that The 3M Company has the necessary equipment, facilities, personnel and quality controls to manufacture the components listed in this report, according to Factory Mutual Research Approval requirements.
- 9.2 Periodic, unannounced Facilities and Procedures Audits will be conducted to determine that the quality and uniformity of the component parts being used in the manufacture of Factory Mutual Research Approved windstorm resistant fenestration units is being maintained and that they are providing a level of quality equivalent to that originally tested and approved.
- 9.3 Factory Mutual Research Approval recognition is contingent upon satisfactory results of the follow-up Facilities and Procedures Audits.
- 9.3.1 Unsatisfactory results of Facilities and Procedures Audits may result in additional Facilities and Procedures Audits as deemed necessary by Factory Mutual Research or forfeiture of Approval recognition.

Test Report By: Mark D. Tyrol. Project Engineer

REPORT ISSUED BY:



Jeffrey E. Gould
Assistant Manager
Materials Section

REVIEWED BY:



George A. Smith
Manager
Materials Section

Attached:

Appendix A: 3M™ Scotchshield™ Ultraflex Windstorm Glazing Protection Details (3 pages)

Appendix B: New Installation Assembly Details (4 pages)

This system must be installed by an authorized 3M film dealer. Read and understand all installation instructions before beginning.

The intended use of this system is to anchor the applied film to the window frame. The condition of the frame and the condition and style of the frame attachment to the building is beyond the scope of this application.

Windload and explosive blast testing associate with this product were done on typical commercial style frames. The inherent strength and structural integrity of other types and brands of frames may be different.

Silicon adhesive must extend at least 3/8 inch (9.5mm) on the frame and 3/8 inch (9.5 mm) on the glass above the level of the frame. Refer to the attached instruction sheet for details.

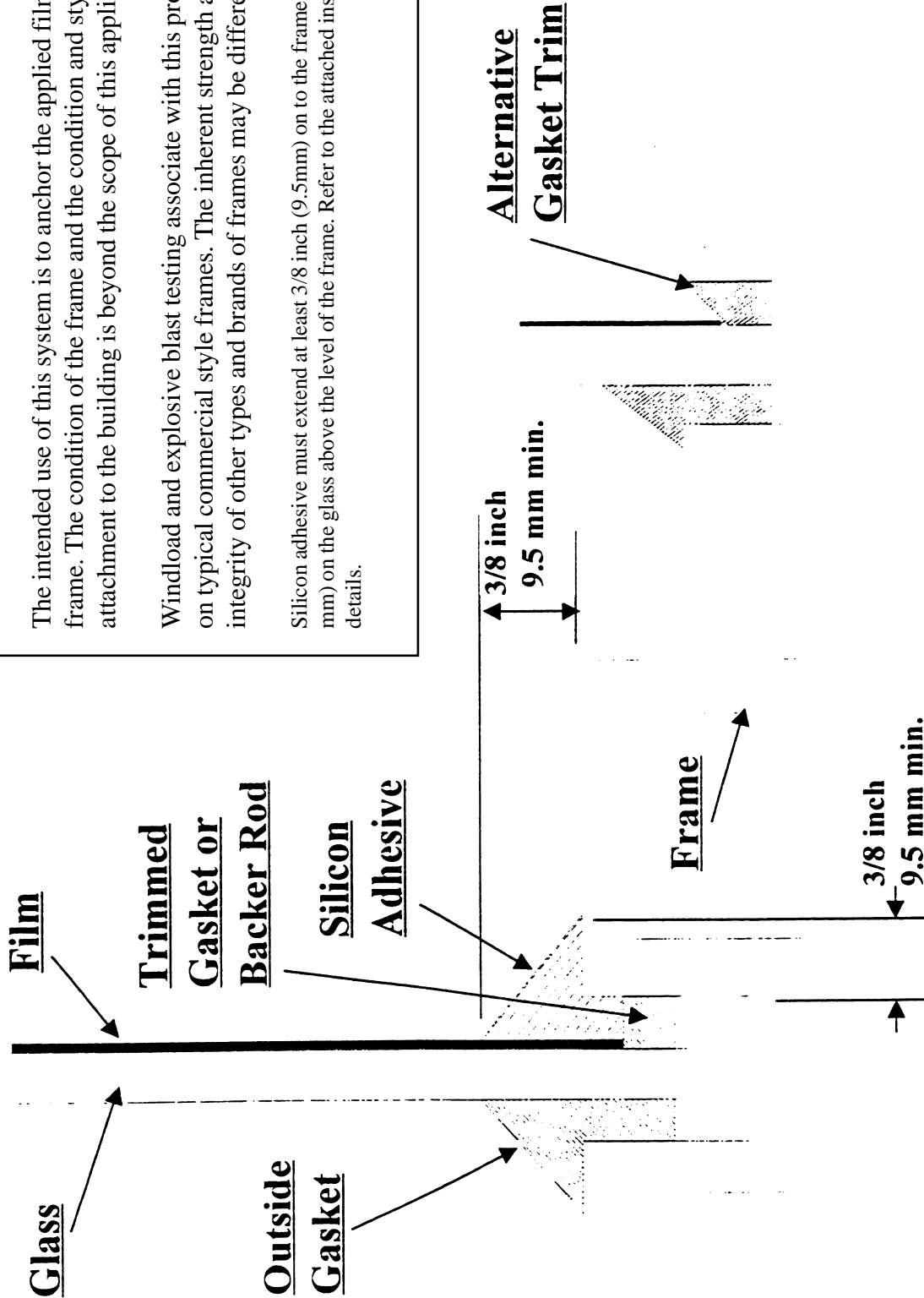

FMRC
J.I. ID3A9 AM
APPENDIX A
ILLUSTRATION
1 of 3

Drawing No. SCPD-USS-001
3-Specified Construction
Products Department

Revision
C

3M™ Ultraflex Sealant System

HETI
8532 N.W. 64 St
Miami, FL 33168
(305) 597-5590

TESTED → GLAZING DETAIL

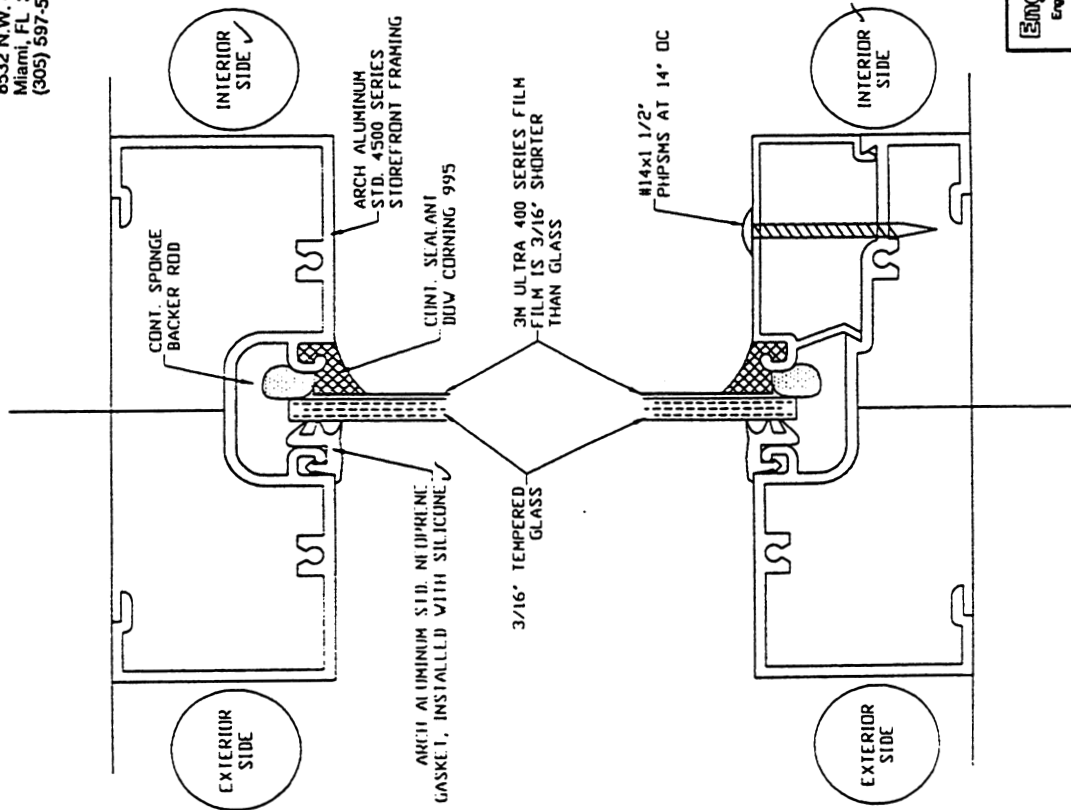

TESTED → CORNER DETAIL

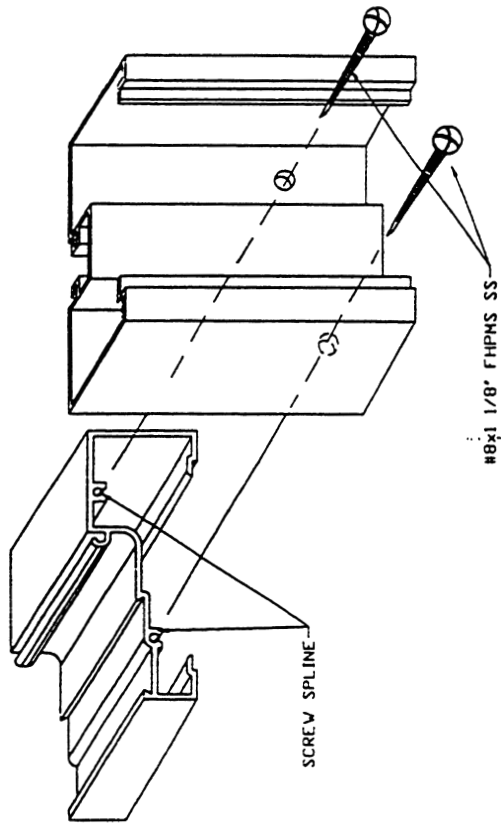

Engco, Inc.
Engineering Services
Central
8607 NW 7th BL
Pensacola, Florida - 33324
Tel.: 904-624-0884

[Signature]
Pedro De Figueiredo
PE 32809

HE 1000 Series Roll Shutters
3M
Reg. 207, Inc. 08
P.O. Box 1007, 5144-1000
Tel.: 801-736-1818

Rev.	Description	Date	Scale	1/2"-1"	Designed by	Date

SHEET
2 of 2
Drawing Number
077-991

Ultraflex Window System Installation Instruction

The following procedure describes the materials and steps that are necessary to install the structural adhesive attachment as part of the 3M Ultraflex Window System.

Products Recommended

3M™ Citrus Base Cleaner (3M I.D. No. 62-461-4930-5)
3M™ Adhesive Remover. Citrus Base (62-4667-292-8)
3M™ Foaming Glass Cleaner (70-0708-2870-5)
3M™ 0000. Super Fine Synthetic Steel Wool Pad (70-0706-5285-7)
3M™ Scotch™ Safe Release™ Masking Tape (98-0701-1931-2)
3M™ Scotch™ Long Mask™ Masking Tape (98-0701-3183-8)

Ultraflex Preparation

1. A thorough cleaning of the glazing and frame systems before applying film is recommended. Removal of all foreign matter and contaminants such as adhesives, crease, oil, dust, water, surface dirt, old sealant or glazing compounds by using a 3M Citrus Base cleaner, alcohol or commercial cleaning solution. **Detergent or soap and water treatments are not recommended for this step.**
2. Spray the glazing bead, glass and frame surface with the solution of choice. Let stand for 5 minutes, then wipe off the solution with a clean oil-free and lint-free cloth. If the area is particularly dirty a light scrub with a 3M, 0000, Synthetic Steel Wool Pad is recommended to loosen contaminants. A second application of the solution and final wipe with a lint-free cloth should make sure that all contaminants are removed.
3. Spray the glass with a 3M Foaming Glass Cleaner or soap and water solution. Flush the glazing bead to glass area starting at the top and working down to drain or remove any remaining contaminant from the area. Scrape the glass with a razor to remove all foreign matter, then thoroughly clean the glass a final time with a lint-free cloth or a squeegee wipe. Wipe around the glazing bead one final time to remove all the water/soap solution.
4. Starting at the inside top center cut the glazing bead material with a razor knife or blade. Smaller gaskets 1/2" (12mm) or less should be cut at a 45° angle so that the blade cuts down into the glass glazing channel, this will form a sealant channel. Larger glazing beads can be cut 90° to the glass, removing the top portion of the bead leaving the anchor portion in the glazing channel. Cut to within 3 inches (75mm) of each of the corners. **Be careful not to scratch into the glass surface when performing this step.**
5. Cut squarely out from where you stopped at the corner positions and remove the cut glazing bead material. **Remember to leave the uncut glazing bead in the glazing.**

10/01/99

- 1 - Ultraflex Installation Instructions

channels and the uncut gasket portion in the corners. This will help to act as backer material when applying the sealant material to the glazing channel and not allow sealant to penetrate into the glazing channel. The corner pieces will help keep the glass secure to the frame. **It is important not to compromise the integrity of the seal to the outside gasket.**

6. The inside-glazing bead can be trimmed and removed for most residential frames, e.g., patio doors. For larger architectural panels, small sections of the cut glazing bead material can be reinstalled along the glazing edge to secure the glass panel or short 1" (25mm) sections can be left in place along the edge when cutting. If the gasket material is totally removed, backer-rod filler can also be used to fill the void. **Backer rod: A small diameter rod with low modulus is easier to install. Be careful not to push backer rod too far into glazing channel. A plastic glazing tool or your fingers works well for this application.**
7. Make sure that all remaining residue is removed from the glazing channel, particularly along the top and side channels. This will reduce the amount of contaminant that can be washed into the adhesive when the film is applied.

Film Installation

1. Apply the 3m™ Scotchshield™ Ultra Window Film to the glass making sure that the film is installed as far into the glazing channel as possible. Cut film as you normally would around the remaining glazing bead. **Remember to leave enough spacing between film and glazing bead to facilitate the removal of the slip solution.**
2. Squeegee the film to the glass by pressing firmly to remove as much of the slip solution as possible, especially at the edges of the film.

Two 'edge-drying' methods can be used before applying the Ultraflex system.

- A. The panels can be left for a few weeks to insure proper drying of the film before the Ultraflex system is applied.

-OR-

- B. Using a hair dryer, gently heat and bump the edges of the film to hasten the removal and drying of the water from the edges. **Make sure that all the water/soap solution has been removed from the film/glass/glazing channel before applying the Ultraflex structural adhesive system.**

Structural Adhesive Installation

Using 3M™ Scotch™ brand. Safe-Releaser™ White Masking Tape apply a 1" (25mm) strip of tape to the Scotchshield Ultra film surface 3/8" (9mm) in from the edge of the film all four sides.

1. Using 3M Scotch™ brand. Long-Mask™ Blue Masking Tape apply a 1" (25mm) strip of tape to the frame system 3/8" (9mm) in from the frame/glass edge. This will form a parallel sealant channel that will allow a uniform sealant bead to be applied to the glass/frame interface. **A minimum of 3/8" (9mm) overlap is necessary to form an approved bond to the frame/film interface.**

Note: Use a clean drop cloth before proceeding to next step.

2. Using Dow Corning 1995 Silicone Structural Adhesive apply a sealant bead into the channel formed by the tape. **Read and follow all product information and installation instructions provided by Dow Corning.** We recommend you start in a corner and pull the sealant bead out approximately 6 inches. Then turn the gun and push the sealant bead to the next corner, where the same method is repeated. **Pushing the sealant bead will insure proper penetration and minimize the chances of air gaps in the bead.** Pulling the gun can also be done if confident no air gaps are formed.
3. Smooth the sealant bead with an appropriate tool. if necessary, to give a finished look. Tooling should be completed in one continuous stroke immediately after sealant application and before a skin forms (approximately 10-20 minutes).
4. Remove the two masking strips from the glass/frame carefully as soon after tooling as possible. Do not allow the excess structural adhesive to contact the film, frame or flooring surfaces. A plastic throwaway drop cloth or garbage bag below the installation can be helpful for this. **Be careful not to step on adhesive and transfer to carpeting, floors or anywhere else.**

Note: Should you get some of the structural adhesive on the surrounding surfaces an application and gentle wipe with the 3M Adhesive Remover Citrus Base cleaning solution can be used.

Curing times may vary depending on temperature and relative humidity. It is not recommended to clean the film/Ultraflex system for at least 24 hours following the installation. Full curing/adhesion can take up to 21 days, depending on conditions.

IMPORTANT NOTICE: 3M MAKES NO PERFORMANCE PROMISES OR OTHER REPRESENTATIONS ABOUT THE EFFECTIVENESS OF THE ULTRAFLEX WINDOW SYSTEM FOR USE WITH 3M WINDOW FILM IN A PARTICULAR APPLICATION.

All statements, technical information and recommendations contained in these Ultraflex Window System installation instructions are based on tests believed to be reliable. However, many factors beyond the control of 3M can affect the use and performance of the 3M products in particular applications. Because these factors are uniquely within the user's knowledge and control, it is

essential that the user evaluates and determines whether the 3M Window Film and/or Ultraflex Sealant System are appropriate for the particular application.

10/01/99

-4 - Ultraflex Installation Instructions



Window Film Depot

Call 866-933-3456 for a professional assessment or email us at: support@windowfilmdepot.com